

**Ecosystem Change and the Decline of
Marine Mammals in the Eastern Bering Sea:
Testing the Ecosystem Shift and
Commercial Whaling Hypotheses**

by

**Andrew W. Trites, Patricia A. Livingston¹, Steven Mackinson,
Marcelo C. Vasconcellos, Alan M. Springer² and Daniel Pauly**

*Fisheries Centre, University of British Columbia, 2204 Main Mall
Vancouver, B.C. V6T 1Z4 (604) 822-8181*

¹ *National Marine Fisheries Service, 7600 Sand Point Way NE, Seattle, WA 98115*

² *Institute of Marine Science, University of Alaska, Fairbanks, Alaska 99775 1080*

published by

The Fisheries Centre, University of British Columbia

***2204 Main Mall
Vancouver, B.C., Canada***

1999

ISSN 1198-6727

This report should be cited as follows:

Trites, A.W., P.A. Livingston, M.C. Vasconcellos, S. Mackinson, A.M. Springer, and D. Pauly. 1999. Ecosystem change and the decline of marine mammals in the Eastern Bering Sea: testing the ecosystem shift and commercial whaling hypotheses. Fisheries Centre Research Reports 1999, Vol. 7 (1), 106 p.

Summary

Some species in the Bering Sea underwent large changes between the 1950s and the 1980s. Among the best documented are the declines of Steller sea lions and northern fur seals, and the possible increase and dominance of ground fish – pollock and large flatfish. A frequently proposed explanation is that human exploitation of top predators and/or a shift in the physical oceanography altered the structure of the eastern Bering Sea ecosystem.

We employed two inter-related software packages (Ecopath and Ecosim) to describe quantitatively the eastern Bering Sea ecosystem during the 1950s, before large-scale commercial fisheries were underway, and during the 1980s, after many marine mammal populations had declined. We grouped the hundreds of species that make up the Bering Sea ecosystem into 25 functional groups.

Our mass-balance ecosystem models showed that most of the top predators (trophic level IV) declined from the 1950s to the 1980s. They included Steller sea lions, seals, sperm whales, deep-water fish and other demersal fishes. The only top predators to increase were large flatfish such as arrowtooth flounder. At the mid-trophic level (III), baleen whales and pelagic fishes declined, while small flatfish, pollock, and walrus and bearded seals increased. Based on our model assumptions, pollock contributed over 50% of the total flow of energy at the mid trophic levels during the 1980s compared to only 10% in the 1950s model. In contrast, pelagic fishes contributed nearly 50% of the flow in the 1950s. At trophic level IV, no one species dominated the flow of energy during the 1950s. However, large flatfish contributed over 60% of the total energy flow in the 1980s model. Large flatfish and adult pollock that dominate the Bering Sea in the 1980s appear to be significant competitors of seals. Large flatfish are also competitors of Steller sea lions and there are large overlaps in the diets of pollock and baleen whales.

Changes in the biomass of marine mammals appear to have little effect on the biomass of other groups in the Bering Sea. Reductions in prey abundance can quickly reduce marine mammal populations, but marine mammals are unable to quickly recover when abundant food becomes available. Our models suggest that Steller sea lion populations would be larger if adult pollock and large flatfish were lower in abundance due to competitive release of important prey.

Most impacts on the modeled ecosystem can be associated with changing the biomass of lower trophic levels. Total catch in the eastern Bering Sea rose from 0.33 to 2.62 $\text{t}\cdot\text{km}^{-2}$ between the 1950s and the 1980s. Exploitation during the 1950s used 47% of the net primary production, with most of it flowing through the harvested whales. Shifting the emphasis from exploiting marine mammals in the 1950s to catching fish in the 1980s lowered the amount of primary production required to sustain harvests to 6%.

Some ecosystem indices derived from our ecosystem models indicate that the eastern Bering Sea was more mature in the 1950s than in the 1980s. However, we are less certain about the actual state of the Bering Sea in the 1950s due to the relative paucity of data from that time. The ecosystem indices for both the 1950s and 1980s models suggest that the Bering Sea is relatively resilient and resistant to perturbations. Removing whales from the 1950s ecosystem had a positive effect on pollock by reducing competition for food. However, whaling alone is insufficient to explain the 400% increase in pollock biomass that may have occurred between the 1950s and the 1980s. Nor can commercial fisheries account for these observed changes. The magnitude of changes that occurred in the biomass of all the major groups in the eastern Bering Sea cannot be explained solely through trophic interactions. We suggest that other factors comprising a regime shift, such as changes in water temperature or ocean currents may have been at play.

Director's Forward

Testing the Cascade Hypothesis, Indigenous Peoples and the name of the Bering Sea.

There are two reasons why the Bering Sea is mis-named.

First, it already had a name. The Aleuts were one of the first human peoples to populate the islands and shores of what we call the Bering Sea and the Aleut language, which includes a creolised Russian version spoken on Bering Island, calls this sea *Udaadan alagux*, which translates as 'the sea around here' or 'our sea', no different in kind to the Roman's name for the Mediterranean Sea, *mare nostrum*, which also means 'our sea'. Using the local name for the Bering Sea would be a courtesy to the indigenous Peoples of this region who have suffered not the best of treatments as the legacy of their sea's 'discovery' by Europeans.

The second reason the Bering Sea is mis-named is due to a mundane mis-filing of the name given to it by an earlier Russian explorer (filing is sometimes said to be the secret of life). The Imperial Russian archives at Yakutsk in Siberia were something of a backwater in the 15th and 16th centuries. Had they been well managed, we may now refer to the Dezhnyov Sea instead of the Bering Sea. In 1648 Semyon Ivanov Dezhnyov (1605-1673), a Cossack, sailed in search of furs with a fleet of seven ships around the north eastern cape of Asia and landed in Kamchatka, proving the separation of the Asian and American continents. The cape bears Dezhnyov's name, but the records of his journey were not re-discovered until 1736 by a German historian, Gerhard Müller. Unaware that the question had already been answered, in 1724 the Russian Tsar, Peter the Great, commissioned Janasson (Vitus) Bering (1681-1741), a Danish explorer born in the 11th century town of Horsens, Jutland, to determine if there was a northeast passage to China. Bering did just that, but poor weather prevented any detailed exploration, and the Bering Strait was charted in 1730 by Mikhail Gvozdev and Ivan Fyodorov, whose trip was designed to subdue the Chukchi people of the region.

Soon, the Russian Empress Anna, who in 1730 emerged from the turmoil following Peter the Great's sudden death in 1725, commissioned Bering to return to the area again. So, when Müller reported that Dezhnyov had been there first, a century earlier, Bering had already left St. Petersburg to explore the Siberian north, secure in the knowledge that a sea was already named after him. After many hardships, including building a boat in a Kamchatkan winter, Bering, captaining the *St. Paul*, explored much of the Alaskan peninsula and the Aleutian island chain in 1741, and, by his own reports causing much distress to the aboriginal peoples who lived there.

Vitus Bering and his crew, including the naturalist Georg Steller, documented the great wealth of fur-bearing sea mammals in the region, exactly the news that the waiting Russian court wanted to hear. But Bering did not live to take the news home. He died of scurvy after being shipwrecked on Bering Island, one of the Komandorskiye islands, famous also as the home of the Steller's sea cow, *Hydrodamalis gigas*, a unique cold-water sirenian and the first sea mammal to be driven to extinction by human hunting (see Pitcher 1998a). The Russian colonisation of North America had begun inauspiciously, like so many other similar events around the world, with the extinction of indigenous fauna and the abrogation of native people's rights (see Diamond 1997).

Over the two centuries following the sad and final loss of the sea cow, waves of human over-exploitation of marine animals have taken place in the Bering Sea. Known by fisheries scientists as serial depletions, in this process human hunters and fishers shift their geographical focus area by area, and replace target species one by one. In the Bering Sea, sea otters were devastated in the 1700s, fur seals and coastal whales in the 1800s, and the great oceanic baleen whales in the 1900s. In each of these cases our activities have greatly altered natural ecosystems.

But what are these changes? How can we know what we have done to marine ecosystems?

Until recently, there have been almost no scientific tools with which to try to answer these questions. Indeed, there is no end to the mischief that inadequate modelling, unable to address ecosystem linkages, can lend to such questions. The new technique of ecosystem simulation modelling is still in its infancy, but here the ECOPATH and ECOSIM suite of techniques are used to address a specific hypothesis about human-caused changes in the Bering sea. ECOPATH is a mass-balanced snapshot of an aquatic ecosystem that explicitly quantifies all trophic interactions, while ECOSIM allows dynamic simulations of the model biomass pools. Seven previous Fisheries Centre Research Reports have dealt with this type of ecosystem modelling: Bonfil et al. (1998), Pauly (1998), Pauly *et al.* (1998a), Okey and Pauly (1998), Dalsgaard and Pauly (1997), Pauly and Christensen (1996), and Pitcher (1996).

In this report, these models are employed in a test of the *competitive release hypothesis*, also termed a *cascade hypothesis*, as proposed in NRC (1996), that removing whales will increase numbers of fish and other organisms that share whale food, mainly euphausiids. From an evolutionary perspective, there is no doubt that competitive interactions, and their avoidance, has shaped the life histories and trophic niches of most species that we observe in marine ecosystems. The problem is that ecologists have had great difficulty in validating such interactions operating in the wild. Data is always said to be insufficient, or evidence equivocal, while some aver that, without field experiments, proof of such effects is impossible (see Hall 1999). The usefulness of the ECOPATH/ECOSIM ecosystem simulation modelling system is that these questions can be investigated by comparing a range of scenarios.

Each ECOPATH model represents a huge amount of information culled from literature and research work. Models of this kind can summarise the research of many workers in constructing the dynamics of the trophic web upon which ECOSIM simulations of may be based. In the present work, the ECOPATH models have 26 component biomass pools. The ECOPATH/ECOSIM modelling system is by no means perfect, and at present is not able to capture some ecological processes such as the structural changes caused by keystone species. But this problem can be addressed by modifying scenarios of the models to represent the past, present and future of an ecosystem, a process termed *Back to the Future* modelling (Pitcher 1998b; Haggan *et al.* 1998; Pitcher *et al.* 1999). And, in addition, such models may be refined without disputing or replacing previously acquired information about the ecosystem, and so provide a basis for ongoing tests of a range of hypotheses about actual changes that have been observed. Hence, this report may not be the final answer on the Bering Sea whale-fish interaction question, but future work may be easily based upon what is reported here. For example, it would be valuable to try to increase precision by incorporating the knowledge of local indigenous peoples in building models of the past. Such knowledge is extremely valuable, especially for times before scientific data was collected, and may have an important bearing on the questions examined in this report.

The *Fisheries Centre Research Reports* series publishes results of research work carried out, or workshops held, at the UBC Fisheries Centre. The series focusses on multidisciplinary problems in fisheries management, and aims to provide a synoptic overview of the foundations, themes and prospects of current research. Fisheries Centre Research Reports are distributed to appropriate workshop participants or project partners, and are recorded in Aquatic Sciences and Fisheries Abstracts. A full list appears on the Fisheries Centre's Web site, <http://fisheries.com>. Copies are available on request for a modest cost-recovery charge.

Tony J. Pitcher
Professor of Fisheries
Director, UBC Fisheries Centre

Acknowledgements

This study was funded by a grant from the David and Lucile Packard Foundation. We are also grateful for the additional support provided by the North Pacific Marine Science Foundation through the North Pacific Universities Marine Mammal Research Consortium. We would also like to thank Pamela Rosenbaum for her administrative assistance, and Paul Spencer and Beth Sinclair of the Alaska Fisheries Science Center for providing constructive comments on our report.

Table of Contents

Summary	3
Director’s Forward	4
Acknowledgements	6
Table of Contents	7
Introduction	9
An Overview of Ecopath & Ecosim	10
Eastern Bering Sea – Defining the System	11
Species Assemblages of the Eastern Bering Sea	13
Balancing the Ecosystem	14
Balancing the 1980s model.....	15
Balancing the 1950s model.....	15
Ecopath Model Results	19
Flow Charts & Trophic Levels	22
Niche Overlaps	26
Mixed Trophic Impacts	27
Fisheries	29
Characterizing the Bering Sea Ecosystem.....	30
Ecosim Model Results	34
Equilibrium Simulation Results	36
Dynamic Simulation Results	42
System Recovery Time	50
Discussion of Simulation Results.....	51
Conclusions	52
Literature Cited	54
Appendix 1 – Mass-Balance Model Details	72
ECOPATH - steady state mass-balance ecosystem model.....	72
ECOSIM - dynamic mass-balance approach for ecosystem simulation.....	72
Appendix 2 – Species Assemblage Details	74
<i>Mammals and Birds</i>	74
1. Baleen Whales	77
2. Sperm Whales.....	80
3. Toothed Whales	81
4. Beaked Whales	83
5. Walruses and Bearded Seals	83
6. Steller Sea Lions	84
7. Seals	84
8. Piscivorous Birds.....	87

<i>Fish and Cephalopods</i>	87
9,10. Pollock	89
11. Deepwater Fish	89
12. Large Flatfish	89
13. Small Flatfish	90
14. Pelagics	90
15. Other Demersal fish	91
16. Cephalopods	91
<i>Benthics and Jellies</i>	92
17. Benthic Particulate Feeders.....	92
18. Infauna.....	92
19. Jellyfish	93
20. Epifauna.....	93
<i>Plankton</i>	94
21. Large Zooplankton	94
22. Herbivorous Zooplankton.....	94
23. Phytoplankton.....	95
<i>Other</i>	95
24. Discards and By-Catch	95
25. Detritus.....	96
Appendix 3 – Parameters for the 45-Box Ecopath Model.....	98
Appendix 4 – Diet Matrix Tables	99
Appendix 5 – Niche Overlap Tables	103

Introduction

The Bering Sea has supported considerable indigenous and commercial demand for fish, crustaceans and marine mammals over the past century. Despite a variety of regulations to safeguard fish, mammals and birds, some species in the Bering Sea and Gulf of Alaska have undergone large and sometimes sudden population fluctuations (NRC 1996). Among the best documented changes are the declines of the Steller sea lions and northern fur seals between the 1950s and 1990s, and the increase and dominance of a bottom fish – pollock and large flatfish – since the late 1960s.

A frequently proposed explanation for events over the past few decades is that a combination of changes in the physical oceanography acted in concert with human exploitation of top predators. Impacts on trophic levels may have cascaded and shifted the North Pacific ecosystem to one dominated by pollock. For example, the mass removals of whales, plus the large declines of Pacific Ocean perch, herring, and yellowfin sole populations during the 1960s, resulted in the rapid loss of several million tonnes of biomass. Such an abrupt change in biological constraints in the system may have had cascading effects that led to new patterns of energy flow through food webs and may have affected other species at other trophic levels. These changes could have caused the recent declines of sea lions, harbor seals, fur seals, and certain seabirds (Merrick 1995, NRC 1996).

Although a scenario of this sort is a likely explanation for events in the Bering Sea and Gulf of Alaska, no rigorous testable hypothesis has been developed. This is due in part to gaps in our understanding of the ecosystem components, but mostly to the lack of ecosystem oriented approaches that explicitly take into account trophic inter-dependencies (*c.f.* Laevastu and Favorite 1977).

Fisheries scientists throughout the world largely agree that they must find ways to account for species interactions. The emerging shift of fisheries research from single-species analysis towards an ecosystem-based approach requires tools that explicitly account for ecological interactions, especially those of a trophic nature. Two such tools, which we employ, are Ecopath and Ecosim (Christensen and Pauly 1992a,b, 1995; Walters *et al.* 1997). These are software packages that explicitly describe trophic relationships between marine species and simulate changes over time.

The following describes two formal representations of the Bering Sea ecosystem – one for the 1950s, before large-scale commercial fisheries were underway, and the second for the 1980s, after many populations of marine mammals had declined. We use these models to examine how the structure of marine communities in the eastern Bering Sea may have changed in response to different fishing, harvesting and climate regimes. The models also allow us to address whether the physical environment acted in concert with human exploitation of top predators to shift the ecosystem into a new domain. We can test whether the harvesting of whales affected the stability of the Bering Sea, or

whether the niche once occupied by whales is now filled by pollock. We can also examine how marine mammals might respond to changes in fishing pressure.

We begin with a brief description of Ecopath and Ecosim, and the methods used to compile data on the numbers, distribution, diets, and productivity of 25 groups of marine organisms inhabiting the Bering Sea. Detailed descriptions of each group of species are contained in an adjoining appendix. We present a flowchart showing trophic interactions and energy flow in the eastern Bering Sea, and describe how the ecosystems of the 1950s differed from that of the 1980s. We then explore how the ecosystem changed over time and how the structure and dynamics of fish, bird and marine mammal assemblages were affected by human activities.

An Overview of Ecopath & Ecosim

The Ecopath software is a simple approach for analyzing trophic interactions in fisheries resources systems (Christensen and Pauly 1992a,b, 1995). Ecopath is based on the earlier work of Polovina (1984), and is being widely applied to aquatic systems (Christensen and Pauly 1993, Pauly and Christensen 1995). It is a mass-balance approach that describes an ecosystem at steady-state for a given period. Further development of this steady-state model has resulted in a dynamic ecosystem model called Ecosim that is capable of simulating ecosystem changes over time (Walters *et al.* 1997). Ecopath and Ecosim represent all of the major components of the ecosystem, and their feeding interactions, but are relatively simple. These kinds of models readily lend themselves to answering simple, ecosystem wide questions about the dynamics and the response of the ecosystem to anthropogenic changes. Thus, they can help design policies aimed at implementing ecosystem management principles, and can provide insights into the changes that have occurred in ecosystems over time.

Ecopath models rely on the truism that:

$$\textit{Production} = \textit{biomass accumulation} + \textit{fisheries catch} + \textit{mortality due to predation} + \textit{other mortality} + \textit{loss to adjacent systems}.$$

This applies for any producer (e.g., a given fish population) and time (e.g., a year or season). Groups are linked through predators consuming prey, where:

$$\textit{Consumption} = \textit{production} + \textit{non-assimilated food} + \textit{respiration}.$$

The implication of these two relationships is that the system or model is mass-balanced (i.e., biomass is 'conserved', or accounted for in the ecosystem). This principle of mass conservation provides a rigorous framework – formalized through a system of linear equations – through which the biomass and trophic fluxes among different consumer groups within an ecosystem can be estimated (Christensen and Pauly 1995; also see Appendix 1 for additional details).

Constructing an Ecopath model emphasizes ecological relationships rather than mathematical equations. All that is required are the types of data that are routinely collected by fisheries scientists and marine biologists. The model can incorporate and standardize large amounts of scattered information – information that might have otherwise languished in scattered journals, reports and filing cabinets (Christensen and Pauly 1995).

Ecopath is essentially a large spreadsheet that is simultaneously keeping track of all the species and all the feeding interactions occurring within the ecosystem. It describes the ecosystem at one point in time. Ecosim, which is based on the Ecopath equation, simulates how a change in one or more components might affect the ecosystem over time.

Ecopath and Ecosim have been widely applied in recent years. More than 80 Ecopath systems have so far been published world-wide. They span a diversity of systems including upwellings, shelves, lakes and ponds, rivers, open oceans and even terrestrial farming systems (see Christensen and Pauly 1992a,b, 1995; Walters *et al.* 1997; and the Ecopath home page at <http://www.ecopath.org>).

Eastern Bering Sea – Defining the System

The area we delineated in the eastern Bering Sea encompasses the region covered by the Alaska Fisheries Science Center's bottom trawl surveys of the shelf and slope down to 500 m (Fig. 1). It covers a wide range of marine habitats that includes shelf and slope regions, but was treated as a single homogenous area. Nearshore fauna and the northern portion of the Bering Sea were not considered. We chose these boundaries based on the availability of assessment data collected systematically for fisheries and marine mammals. Total area is 484,508 km².

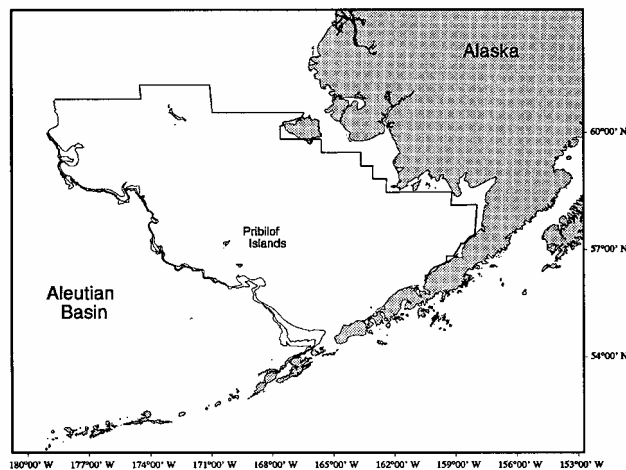

Fig. 1. The eastern Bering Sea as defined in the ecosystem model. Total area is approximately 500,000 km².

Ecopath models were constructed for two periods: (i) **the '1950s'** covering the period 1955 to 1960 and (ii) **the '1980s'** covering the period 1979-1985. Both are annual average models which means that the biomass, and the diets and species composition of summer and winter are averaged to provide a year round 'annual average'. Annual average models are better than seasonal models for examining long-term changes because they are not overwhelmed by seasonal differences in species abundance and composition. However, information on seasonal changes is lost.

Six parameters are required for each species group included in the ecosystem model. They include their

- **biomass** (the total weight of all age classes);
- **diet composition** (the fraction of their diet made up of different species);
- **consumption** (the total amount they eat per year);
- **production** (accumulated biomass plus the amount that was harvested, eaten by other species, or died of other causes);
- **ecotrophic efficiency** (the fraction of production that is exported or passed up the food web); and
- **export** (the amount that is caught or migrates out of the ecosystem).

Each species in the ecosystem model is represented by a single equation containing these 6 parameters. All of the linear equations must be consistent with one another to account for all of the energy flowing in the ecosystem. This means that the Ecopath model can estimate a missing parameter for each equation, so long as there are more equations (i.e., species groups) than unknown parameters. This is a simple algebraic technique (solving for unknowns) and is a useful means for deriving hard to get estimates.

A couple of the parameters can be estimated in roundabout ways. Production, for example, can be estimated from the ratio of production (P) to biomass (B). This ratio (P/B) is equivalent to the instantaneous rate of total mortality (Z) used by fisheries biologists (Allen 1971). Similarly, consumption (Q) can be expressed as a ratio of consumption to biomass, i.e., Q/B. Dividing P/B by Q/B gives P/Q. This ratio (P/Q) is a measure of gross food conversion efficiency (i.e., the fraction of energy that a species converts into production). In most cases, efficiency ranges from 0.1 to 0.3, which means that most groups consume 3-10 times more than they produce.

Species Assemblages of the Eastern Bering Sea

There are hundreds of species in the Bering Sea ranging from tiny phytoplankton, through invertebrates, fish, birds and mammals. Many of the species inhabit the Bering Sea year round while others are seasonal migrants. Creating a separate box in our ecosystem flow chart for each of the species would require an enormous amount of information and detail. Such detail may not enhance our understanding of the ecosystem, and may detract from gaining insight into the components that interest us most. Fortunately many species share functional similarity in an ecosystem and can be aggregated into 'functional groups', each represented by an Ecopath box.

We began by considering 45 groupings of species in the eastern Bering Sea ecosystem. Using data (see following) on biomass, production, consumption, trophic level and diet composition, we used the 'user-controlled aggregation' option in Ecopath to further aggregate these 45 groups. We selected the groups to be aggregated and did not use the automatic aggregation option. We sought similarities in biological rates (P/B and Q/B), taxa and diet composition, and arrived at the following 25 boxes:

Mammals and Birds

1. Baleen whales - *Fin, Minke, Blue, Humpback, Bowhead, Right, Gray*;
2. Sperm whales;
3. Toothed whales - *Beluga, Killer, Dalls porpoise, Harbour porpoise*;
4. Beaked whales - *Stejnegers spp.*;
5. Pacific Walrus and Bearded Seals;
6. Steller sea lions;
7. Seals - *Northern fur, Harbour seal, Spotted seal, Ribbon seal, Ringed seal*
8. Piscivorous Birds - *murrees, kittiwakes*.

Fish and Cephalopods

9. Adult pollock;
10. Juvenile pollock;
11. Deepwater fish - *Sablefish, rockfish, Macrouridae (rattails)*;
12. Large flatfish - *Halibut, Greenland turbot and arrowtooth flounder*;
13. Small flatfish - *Yellowfin sole, rock sole, Alaska plaice and flathead sole*;
14. Pelagics - *Herring and other pelagic fish (lanternfish, capelin, sandlance, salmon)*;
15. Other demersal fish - *Cod, skates, sculpins, and eelpouts*;
16. Cephalopods - *Squid, octopus*.

Benthics and Jellies

17. Benthic Particulate Feeders. – *Tanner crab, King crab and shrimp*;
18. Infauna - *Clams, polychaetes, other worms*;
19. Jellyfish;
20. Epifauna - *Hermit crabs, snails, brittlestars, starfish*.

Plankton

21. Large Zooplankton - *Euphausiids, Mysids, amphipods*;
22. Herbivorous Zooplankton – *Calanoids*;
23. Phytoplankton.

Other

24. Discards;
25. Detritus.

Summary parameters for the species and aggregated groups are contained in Tables 1 and 2. Choice of parameters and critical assumptions are outlined in Appendix 2. Information gathered from published sources included the numbers or biomass of each group of species living in the Bering Sea; their diets, rates of consumption and production. The two primary data sources for groundfish biomass estimates were surveys or stock assessments conducted by the Soviet Union during the 1950s and the United States National Marine Fisheries Service (NMFS) during the 1980s (see Appendix 2). Population estimates for marine mammals came from Perez (1990), the NRC Report (1996), and the 1987-1988 Marine Mammal Protection Act annual report (NMFS 1988). Estimates for other species were drawn largely from stock assessments performed by NMFS scientists. Diet data for groundfish comes primarily from the groundfish food habits data base of NMFS, while diet data for marine mammals comes primarily from the 1996 NRC Report and references therein. Several assumptions were made with respect to the 1950's model. For groups that had no abundance information from that time period, we assumed they had the same biomass as the 1980's period. We also made assumptions about the diet compositions of animals during that time period, particularly assuming that pelagic fish (herring, capelin, and others) were a more important prey than pollock in the 1950s.

Balancing the Ecosystem

We compiled a large number of parameters to estimate the flows of energy between the 45 boxes we initially chose to describe the eastern Bering Sea ecosystem in the 1980s (Appendix 3). Using the 'controlled aggregation' option in Ecopath, these 45 species groupings were re-grouped into the 25 boxes described above. However, it is unclear at this point, whether the estimates and assumptions we have outlined are reasonable and mutually compatible. One test of our choice of parameters is to determine whether they jointly lead to a balanced ecosystem (i.e., one that is at equilibrium where inputs into the boxes are balanced by the output of these boxes). If our description of the eastern Bering Sea ecosystem balances, there will be sufficient prey to support the food requirements of the predators, and the energy inputs and outputs will balance each other.

A number of approaches can be taken to balance our 1950s and 1980s models. In our case, we estimated the 'ecotrophic efficiencies' (EE) for each of the 25 groups of species. Ecotrophic efficiency is the fraction of production that is exported or passed up the food web. It cannot exceed 1.0 under the equilibrium assumption. An ecotrophic efficiency greater than 1.0 identifies a group that is not receiving sufficient input from lower parts of the food web. It indicates to us that some of the initial parameter estimates may have to be verified or modified. A value less than 1.0 means that more energy is entering than is exiting, with the difference ending up as accumulated detritus or being exported from the ecosystem.

Balancing the 1980s model

Our initial estimates for the 25 species groups were consistent with one another, with four exceptions (Table 1). The changes needed to balance the model included:

- Increasing the phytoplankton biomass from 21 to 32 $t \cdot km^{-2}$;
- Increasing the Q/B ratio of jellyfish from 1.09 to 2.00 $year^{-1}$ to ensure $P/B > (Q/B)/2$;
- Reducing the harvest of walrus and bearded seals by half. (The high ecotrophic efficiency of 2.076 meant that there were either too many seals and walruses harvested or we had underestimated the actual number present.); and
- Reducing the proportion of discards eaten by other species. (This assumes that the groups of species were able to compensate for the reduction in diet coming from discards by consuming comparable increases of their major prey groups).

Balancing the 1950s model

The most important assumptions we had to evoke to balance the 1950s model (Table 2) concerned diet compositions. The most notable was our assumption that pelagic fish (herring, capelin, and others) were a more important prey than pollock in the 1950s. We assumed that pollock were in low abundance during the 1950s, based on information from non-systematic Soviet trawl surveys during that period. Hence, pelagic fish likely comprised the major part of many predator diets.

Table 1. Ecopath parameters describing the 1980s eastern Bering Sea ecosystem with 25 functional groups where P/B is the ratio of production to biomass and Q/B is the ratio of consumption to biomass.

Functional Group	Biomass (t km ⁻²)	P/B (year ⁻¹)	Q/B (year ⁻¹)	Catch (t km ⁻²)
1. Baleen whales	0.394	0.020	11.383	0.000
2. Toothed whales	0.009	0.020	13.108	0.000
3. Sperm whales	0.208	0.020	4.553	0.000
4. Beaked whales	0.001	0.020	10.515	0.000
5. Walrus & bearded	0.074	0.060	11.249	0.004
6. Seals	0.066	0.060	15.926	0.001
7. Steller sea lions	0.019	0.060	12.702	0.001
8. Pisc. Birds	0.006	0.800	60.000	0.000
9. Adult pollock	27.451	0.500	2.640	1.895
10. Juvenile Pollock	6.000	2.500	8.333	0.000
11. Other demersal fish	3.904	0.433	2.226	0.128
12. Large flatfish	1.900	0.400	2.444	0.050
13. Small flatfish	9.161	0.400	2.968	0.211
14. Pelagics	13.644	0.798	3.650	0.212
15. Deepwater fish	0.407	0.400	2.490	0.007
16. Jellyfish	0.048	0.875	2.000	0.000
17. Cephalopods	3.500	3.200	10.667	0.000
18. Benth.Par. feeders	5.800	1.480	7.690	0.108
19. Infauna	46.500	1.373	12.000	0.000
20. Epifauna	5.858	1.578	5.777	0.000
21. Large Zoops	44.000	5.091	22.000	0.000
22. Herb. Zoops	55.000	6.000	22.000	0.000
23. Phytoplankton	32.000	60.000	0.000	0.000
24. Discards	0.000	-	-	0.000
25. Detritus	0.000	-	-	0.000

Table 2. Ecopath parameters describing the 1950s eastern Bering Sea ecosystem with 25 functional groups where P/B is the ratio of production to biomass and Q/B is the ratio of consumption to biomass.

Functional Group	Biomass (t km ⁻²)	P/B (year ⁻¹)	Q/B (year ⁻¹)	Catch (t km ⁻²)
1. Baleen whales	0.696	0.020	13.678	0.084
2. Toothed whales	0.009	0.020	13.108	0.000
3. Sperm whales	0.439	0.020	4.553	0.021
4. Beaked whales	0.001	0.020	10.515	0.000
5. Walrus & bearded	0.054	0.060	11.651	0.006
6. Seals	0.106	0.060	15.577	0.005
7. Steller sea lions	0.029	0.060	12.703	0.001
8. Pisc. Birds	0.006	0.800	60.000	0.000
9. Adult pollock	5.500	0.500	2.640	0.014
10. Juvenile Pollock	0.942	2.500	8.333	0.000
11. Other demersal fish	8.957	0.433	2.226	0.001
12. Large flatfish	1.169	0.400	2.444	0.002
13. Small flatfish	8.530	0.400	2.968	0.105
14. Pelagics	28.869	0.798	3.650	0.083
15. Deepwater fish	1.011	0.400	2.490	0.001
16. Jellyfish	0.048	0.875	2.000	0.000
17. Cephalopods	3.500	3.200	10.667	0.000
18. Benth.Par. feeders	29.000	1.480	7.690	0.010
19. Infauna	75.000	1.373	12.000	0.000
20. Epifauna	8.000	1.578	5.777	0.000
21. Large Zoops	44.000	5.091	22.000	0.000
22. Herb. Zoops	55.000	6.000		0.000
23. Phytoplankton	32.000	60.000		0.000
24. Discards	0.000	-	-	0.000
25. Detritus		-	-	

Our assumption that species consumed more pelagic fish than pollock in the 1950s resulted in nine groups having an ecotrophic efficiency above one:

- Baleen whales EE=6.051;
- Sperm whales EE=2.392;
- Walrus and Bearded EE=1.888;
- Phytoplankton EE=1.410;
- Adult pollock EE=1.415;
- Small flatfish EE=1.042;
- Cephalopods EE=1.052;
- Infauna EE=1.334; and
- Epifauna EE=1.352.

Ecotrophic efficiencies above 1.0 indicate that demand upon them is too high to be sustainable. We know that this was indeed the case for whales (and perhaps walrus). Harvest rates would have had to be 50-85% less to be sustainable, or the populations of walrus and whales would have had to be 2-6 times larger to support the numbers being removed each year (Table 3). Either possibility, or a combination of them, would have reduced the ecotrophic efficiency to 1.0 or less.

Table 3. Reduction in harvest of walrus, bearded seals, and sperm and baleen whales that would balance production. The estimates were calculated by assuming a consumption of zero and no export from the system other than harvest (Under these conditions the Ecopath master equation can be reduced to $B \cdot [P/B] \cdot EE - H = 0$, where $EE = H/P$ and $H = P$ when $EE = 1$).

Group	Current (t km ⁻²)	Modified (t km ⁻²)	Change	
			%	factor
Baleen Whales	0.084	0.0139	83	6.0 x less
Sperm Whales	0.021	0.0088	58	2.4 x less
Walrus & Bearded	0.006	0.003	50	2.0 x less

We changed demands on the other groups with high ecotrophic efficiencies as follows:

- Phytoplankton biomass was increased to 32 t•km⁻² as detailed above;
- We slightly adjusted the relative importance of small flatfish and cephalopods in the diets of other groups;
- Biomass of pollock was increased from 4.32 to 5.50 t•km⁻² (reducing the importance of pollock in the diet of its predators reduced the EE by very little); and
- Infauna was increased from 55 to 75 t•km⁻² and epifauna from 5.8 to 8 t•km⁻², since adjusting the importance of infauna and epifauna in the diets of their predators had a minimal effect on EE.

The only other change required to balance the 1950s ecosystem was to increase the Q/B ratio for jellyfish from 1.09 to 2.00 year⁻¹.

Ecopath Model Results

A flowchart showing trophic interactions and energy flow in the eastern Bering Sea during the 1980s is presented in Fig. 2. It shows the estimated trophic level of each of our 25 functional groups and the relative amounts of energy that flow in and out of each box. Large numbers of flows in the Bering Sea emanate from three species at trophic level III—pollock, small flatfish and pelagic fishes. Major consumers are the top-trophic level IV—predators. They include the marine mammals and birds, as well as large flatfish and deepwater fish.

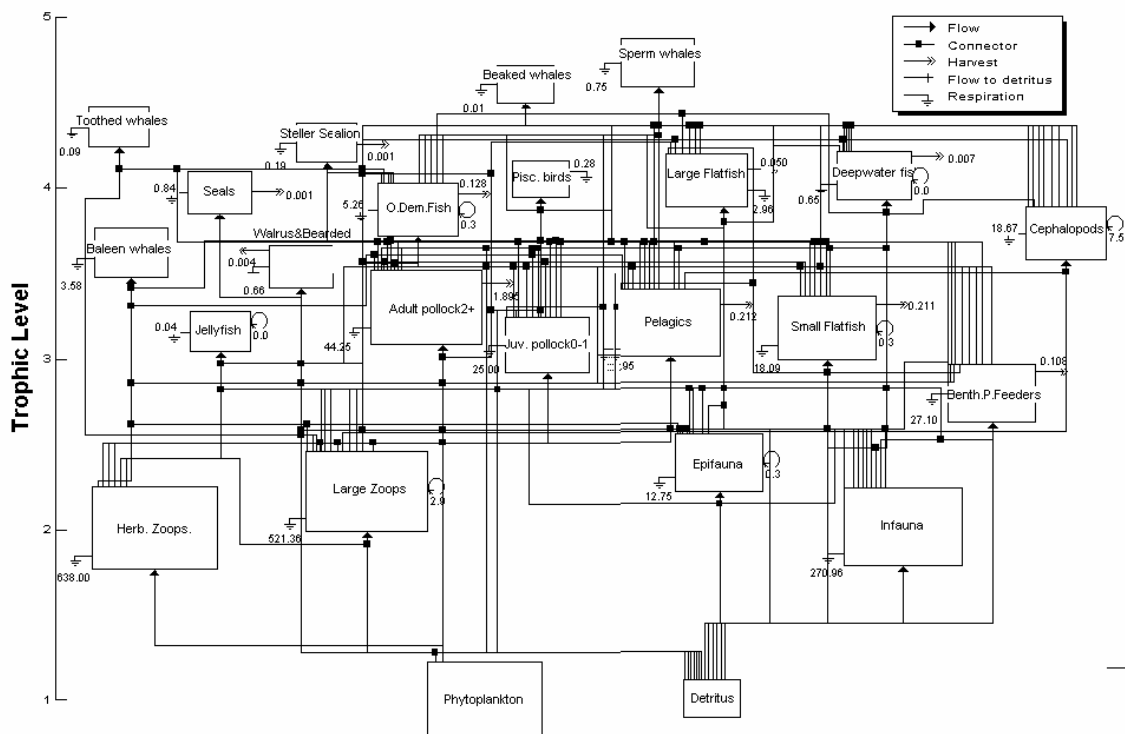

Fig. 2. Flowchart of trophic interactions in the eastern Bering Sea during the 1980s. All flows are in $t \cdot km^{-2} \cdot year^{-1}$. Minor flows are omitted as are all backflows to the detritus. The size of each box is roughly proportional to the biomass therein.

Basic parameters for the 1950s and 1980s ecosystem models are contained in Tables 1 and 2. Changes in biomass between the two modelled time periods are shown in Table 4. Diet compositions are in Appendix 4.

Table 4. Comparison of changes in biomass from the 1950s to the 1980s models.

Functional Group	Biomass (t km ⁻²)		Change (%)
	1950s	1980s	
1. Baleen whales	0.696	0.394	-43
2. Toothed whales	0.009	0.009	0
3. Sperm whales	0.439	0.208	-53
4. Beaked whales	0.001	0.001	0
5. Walrus & bearded	0.054	0.074	37
6. Seals	0.106	0.066	-38
7. Steller sea lions	0.029	0.019	-34
8. Pisc. Birds	0.006	0.006	0
9. Adult pollock	5.500	27.451	399
10. Juvenile Pollock	0.942	6.000	537
11. Other demersal fish	8.957	3.904	-56
12. Large flatfish	1.169	1.900	63
13. Small flatfish	8.530	9.161	7
14. Pelagics	28.869	13.644	-53
15. Deepwater fish	1.011	0.407	-60
16. Jellyfish	0.048	0.048	0
17. Cephalopods	3.500	3.500	0
18. Benth.Par. feeders	29.000	5.800	-80
19. Infauna	75.000	46.500	-38
20. Epifauna	8.000	5.858	-27
21. Large Zoops	44.000	44.000	0
22. Herb. Zoops	55.000	55.000	0
23. Phytoplankton	32.000	32.000	0
24. Discards	0.000	0.000	-
25. Detritus	-	-	-

Various ecosystem indices that relate to resilience, resistance to perturbations, competition between species, and flows between ecosystem elements are shown for the 1950s and 1980s ecosystems in Table 5. These indices, drawn from theoretical ecology (Odum 1969, Holling 1973, Christensen 1995), allow the ecological characteristics of the eastern Bering Sea to be compared over time (1950s-1980s) and with other marine ecosystems (Vasconcellos et al. 1997, Christensen and Pauly 1998). Among the properties of ecosystem models that can be determined are niche overlaps, biomass pyramids, relative contribution of species to the total flow of energy in the ecosystem and the amount of primary production required to sustain marine mammals, fish and fisheries.

Table 5. Descriptive summary statistics for the 1950s and 1980s eastern Bering Sea ecosystem models.

Descriptive Indices	1950s	1980s	Units
Sum of all consumption	3576.11	3073.72	t km ⁻² •year ⁻¹
Sum of all exports	0.33	2.62	t km ⁻² •year ⁻²
Sum of all respiratory flows	1885.15	1620.43	t km ⁻² •year ⁻³
Sum of all flows into detritus	1073.37	994.99	t km ⁻² •year ⁻⁴
Total system throughput	6534.97	5691.76	t km ⁻² •year ⁻⁵
Sum of all production	2679.77	2612.84	t km ⁻² •year ⁻⁶
Mean trophic level of fishery catches	3.44	3.30	-
Gross efficiency (catch/net p.p.)	0.0002	0.0021	-
Input total net primary production	1770	1264	t km ⁻² •year ⁻⁶
Calculated total net primary production	1920	1920	t km ⁻² •year ⁻⁶
Unaccounted primary production	-	-	-
Total primary production/total respiration	0.94	0.78	-
Net system production	115.15	356.43	t km ⁻² •year ⁻⁶
Total primary production/total biomass	5.85	4.94	-
Total biomass/total throughput	0.046	0.045	-
Total biomass (excluding detritus)	302.44	255.95	t km ⁻² •year ⁻⁶
Total catches	0.33	2.62	t km ⁻² •year ⁻⁶
Connectance Index	0.29	0.30	-
System Omnivory Index	0.183	0.157	-

Flow Charts & Trophic Levels

The flow chart depicting the 1950s ecosystem is similar in layout to the 1980s flowchart. It contains the same species at roughly the same trophic levels (Table 6). Where the two systems differ is in the relative sizes of the boxes (i.e., in the biomass of the different functional groups – Figs. 3 and 4).

Groups near trophic level IV that were lower in abundance in the 1980s relative to the 1950s included seals, Steller sea lions, sperm whales, deep water fish and other demersal fishes. The only group that was higher in abundance was large flatfish such as arrowtooth flounder. At the next level down (near trophic level III) pollock, small flatfish and walrus were estimated to have higher biomass in the 1980s relative to the 1950s, while pelagic fishes, such as herring and sand lance, were in low abundance in the 1980s. The 1980s biomass of benthic particulate feeders (crabs), epifauna and infauna was also low.

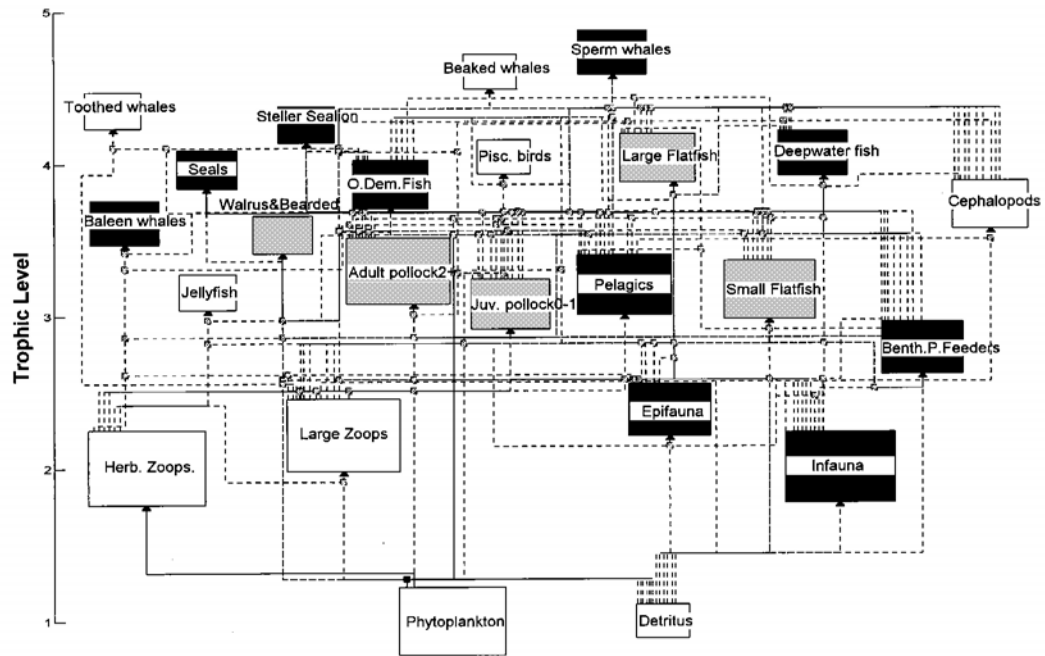

Fig. 3. Flowchart of trophic interactions in the eastern Bering Sea during the 1980s. The blackened boxes indicate which groups had lower estimated abundance in the 1980s than in the 1950s, and the shaded boxes show which species were estimated to have higher abundance in the 1980s than in the 1950s. Connecting lines show the major trophic flows of energy between functional groups (minor flows are omitted).

Table 6. Estimated trophic levels of the 25 groups of species in the 1950s and 1980s models.

	1950s	1980s		1950s	1980s
Sperm	4.75	4.71	Adult pollock	3.34	3.29
Beaked whales	4.59	4.58	Pelagics	3.25	3.20
Toothed whales	4.37	4.33	Small flatfish	3.20	3.16
Steller sea lion	4.30	4.24	Jellyfish	3.16	3.15
Pisc. birds	4.13	4.03	Juvenile pollock	3.09	3.07
Large flatfish	4.12	4.02	Benth.P. feeders	2.82	2.78
Deepwater fish	4.01	4.05	Epifauna	2.63	2.38
Seals	4.01	3.95	Large Zooplankton	2.28	2.22
O. demer. fish	3.82	3.85	Infauna	2.00	2.00
Cephalopods	3.76	3.71	Herb. Zooplankton	2.00	2.00
Baleen whales	3.61	3.60	Phytoplankton	1.00	1.00
Walrus& Bearded	3.51	3.53	Detritus	1.00	1.00

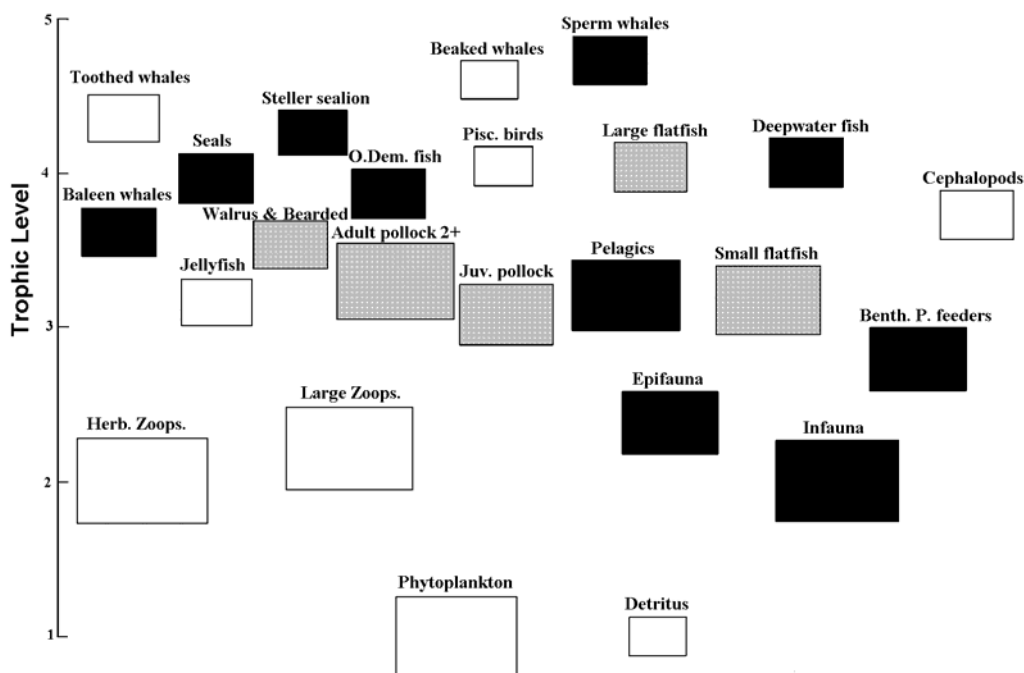

Fig. 4. Estimated trophic levels and relative abundance of species in the eastern Bering Sea during the 1980s. Blackened boxes indicate groups that had lower abundance in the 1980s relative to the 1950s, and shaded boxes show species that had higher abundance in the 1980s relative to the 1950s. Major flows of energy between the boxes are shown in Figs. 2 and 3.

The most important differences between the 1950s and 1980s eastern Bering Sea ecosystem models occurred at the high trophic levels, characteristically occupied by large fish and marine mammals. The relative contribution of the different functional groups to the total flow of energy (expressed in Ecopath as 'throughput' which equals the sum of all flows from consumption, export, respiration, and detritus) was calculated for trophic levels III and IV. At level III (Fig. 5), adult and juvenile pollock contributed almost 50% of the total flow of energy during the 1980s compared to less than 10% during the 1950s. The relative importance of species occupying trophic level III shifted from pelagic species in the 1950s model to pollock in the 1980s model.

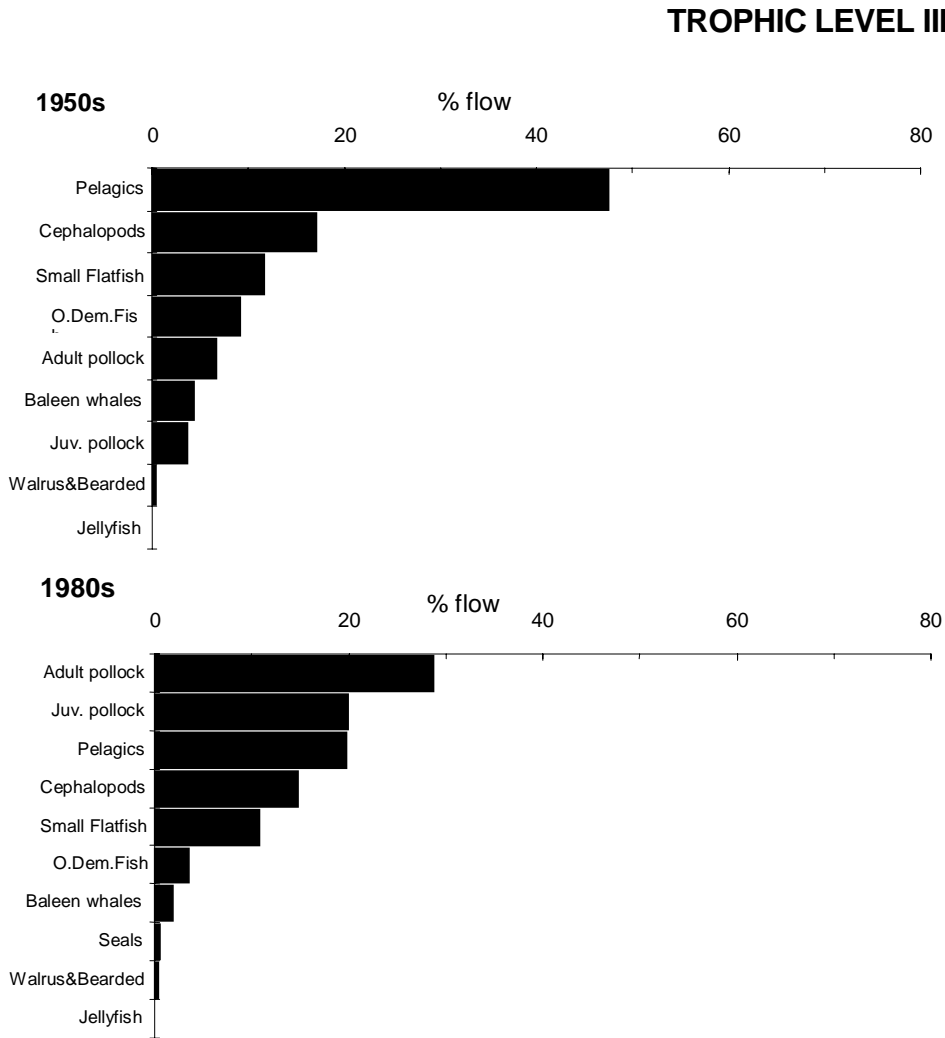

Fig. 5. Relative contribution of species (in %) to the total flow of energy (throughput) at trophic level III in the 1950s and 1980s models. Note that the sum of all bars in each panel equals 100%.

Changes at trophic level IV were mainly due to the increase in the dominance of large flatfishes in the total throughput (Fig. 6). During the 1950s, the flow of energy was much more evenly distributed among species due to the large biomass of seals and sperm whales. Seals fed at a slightly higher trophic level during the 1950s (4.01) compared to the 1980s (3.95, Table 6).

Detritus is an important component of the eastern Bering Sea ecosystem. Total flow originating from detritus rose from 26% in the 1950s to 34% in the 1980s. This rise in throughput from the detritus indicates more groups of species feeding on detritus. Usually a high utilization of detritus indicates a mature (Christensen and Pauly 1998) and resilient ecosystem (Vasconcellos et al. 1997). Our

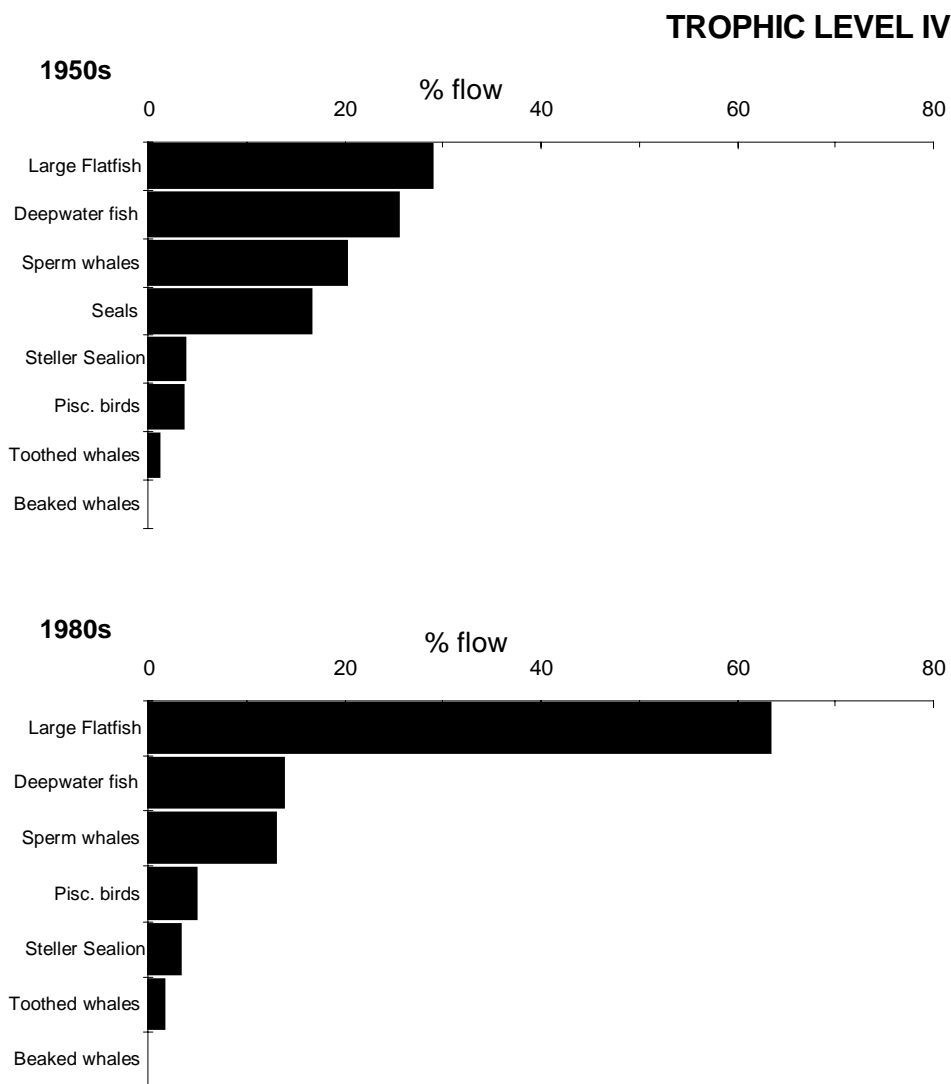

Figure 6. Relative contribution of species to the total flow of energy (throughput) at trophic level IV in the 1950s and 1980s models. Note that the sum of all bars in each panel equals 100%.

interpretation is slightly complicated by our treatment of discards as detritus in the 1980s model. However, calculations by Queirolo et al. (1995) estimate that discards are less than one percent of the total detrital pool in the eastern Bering Sea, an indication that the detrital throughput in the 1980's model is a sign of a more mature benthic ecosystem,

Niche Overlaps

Niche overlaps were calculated between pollock, large flatfish and marine mammals in the 1980's model (Table 7). We took two approaches. One was to determine to what extent any two groups seek the same prey (referred to as prey overlap). The other was to determine to what extent they are subject to predation by the same predators (predator overlap). A value of 1 indicates complete overlap in the resources they share (prey overlap), or in the predators that consume them (predator overlap). A value of 0 indicates that the groups do not share resources or are not preyed upon by the same predators. Both indices are important and can be used to describe various kinds of niche partitioning between groups.

Table 7. Estimated niche overlaps for marine mammals, pollock and large flatfish in the 1980's model. See text for explanation. Dashes indicate no overlap, and values of 0.00 indicate an overlap <0.01. Overlaps ≥ 0.50 are in bold characters.

Prey Overlap										
Group Name	1	2	3	4	5	6	7	8	9	10
1. Baleen whales	1.00	-	-	-	-	-	-	-	-	-
2. Toothed whales	0.48	1.00	-	-	-	-	-	-	-	-
3. Sperm whales	0.30	0.51	1.00	-	-	-	-	-	-	-
4. Beaked whales	0.32	0.74	0.61	1.00	-	-	-	-	-	-
5. Walrus&bearded	0.15	0.29	0.01	0.21	1.00	-	-	-	-	-
6. Seals	0.54	0.66	0.04	0.38	0.39	1.00	-	-	-	-
7. Steller sea lion	0.24	0.49	0.15	0.26	0.09	0.40	1.00	-	-	-
8. Adult pollock2+	0.86	0.16	0.00	0.04	0.06	0.50	0.08	1.00	-	-
9. Juv. pollock0-1	0.73	0.04	-	-	-	0.21	-	0.86	1.00	-
10. Large flatfish	0.26	0.35	0.03	0.15	0.11	0.45	0.38	0.34	0.08	1.00

Predator Overlap										
Group Name	1	2	3	4	5	6	7	8	9	10
1. Baleen whales	1.00	-	-	-	-	-	-	-	-	-
2. Toothed whales	1.00	1.00	-	-	-	-	-	-	-	-
3. Sperm whales	-	-	-	-	-	-	-	-	-	-
4. Beaked whales	-	-	-	-	-	-	-	-	-	-
5. Walrus&bearded	1.00	1.00	-	-	1.00	-	-	-	-	-
6. Seals	1.00	1.00	-	-	1.00	1.00	-	-	-	-
7. Steller sea lion	-	-	-	-	-	-	-	-	-	-
8. Adult pollock2+	0.00	0.00	-	-	0.00	0.00	-	1.00	-	-
9. Juv. pollock0-1	-	-	-	-	-	-	-	0.15	1.00	-
10. Large flatfish	0.05	0.05	-	-	0.05	0.05	-	0.03	0.71	1.00

In terms of who is seeking the same prey in the Bering Sea, baleen whales and pollock (both adult and juvenile) have the greatest dietary overlap 73-86% (niche prey –Table 7). There is also a significant amount of competition between seals and adult pollock, and between adult pollock and pelagic fishes (Appendix 5). Toothed whales compete primarily with beaked whales and seals, while adult pollock share a large proportion of their diet with juvenile pollock. The largest competitors of sea lions appear to be seals, toothed whales and large flatfish (Table 7). Niche overlaps for other species in our model are contained in Appendix 5.

Toothed whales consume adult pollock and other species of whales, but the niche overlap is small (niche predator – Table 7). Similarly, adult and juvenile pollock only have a small overlap in their predators (15%). The fish groups most often targeted by the same predators are juvenile pollock and large flatfish (71%).

Mixed Trophic Impacts

We used a Leontif matrix (see Christensen and Pauly 1992b) to explore the direct and indirect impacts of competition and predation on species in the Bering Sea. The matrix assesses how an increase in the biomass of one group affects the biomass of another (Figure 7). Impacts shown in the figure are relative but comparable between groups. The Leontif matrix shows how changes at one level of the food web affect others (cascade effects) and can be regarded as a form of sensitivity analysis (i.e., how sensitive groups are to changes in the biomass of another group). It can also give some insight into the stability of the ecosystem in terms of its ability to withstand changes.

The mixed trophic impact graph indicates that a change in the biomass of marine mammals has little or no effect on changes in the biomass of other groups. Another obvious feature is that most impacts on the ecosystem are associated with changing the biomass of lower trophic levels. Increasing the biomass at a low or mid trophic level has a positive effect on higher trophic levels (presumably more food is available) and has a negative effect on other low trophic levels (food is presumably reduced through competition).

Increasing the biomass of adult pollock has a positive effect on the fishery and a negative effect on juvenile pollock. Adult pollock cannibalize juvenile pollock and out-compete the seabirds feeding on juvenile pollock (note however that the matrix does not account for an increase in juvenile abundance that should occur through increased recruitment).

Our models assumed that pelagic fishes comprised over 60% of the diet of sea lions in the 1980s and over 80% of the diet in the 1950s. Increasing the pelagic fish population in the models results in increases in the Steller sea lion populations. Pelagic fishes in turn are possibly influenced by the amount of phytoplankton and large zooplankton. Increases in plankton not only benefit Steller sea lions, but they also have positive effects on all of the upper trophic

1950s

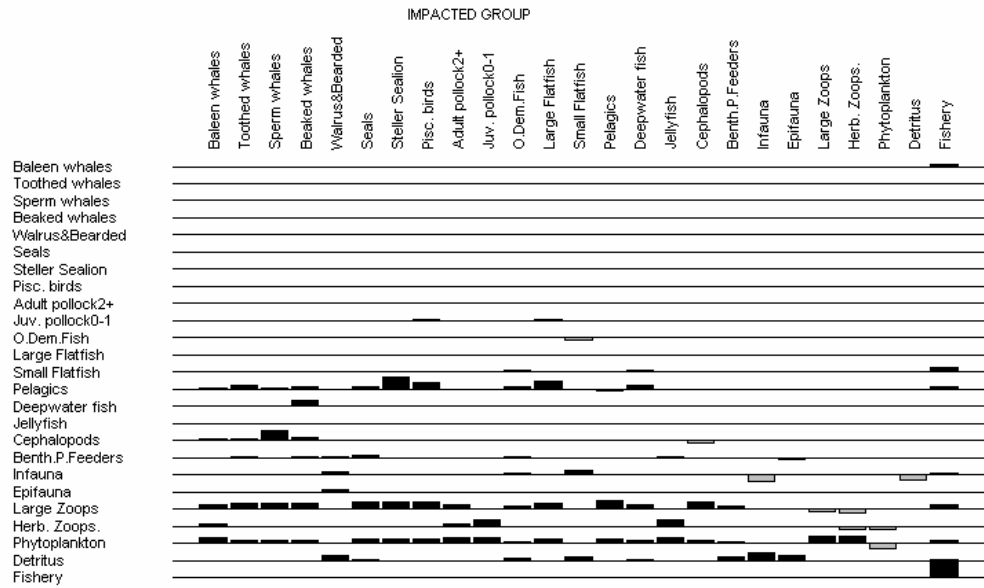

1980s

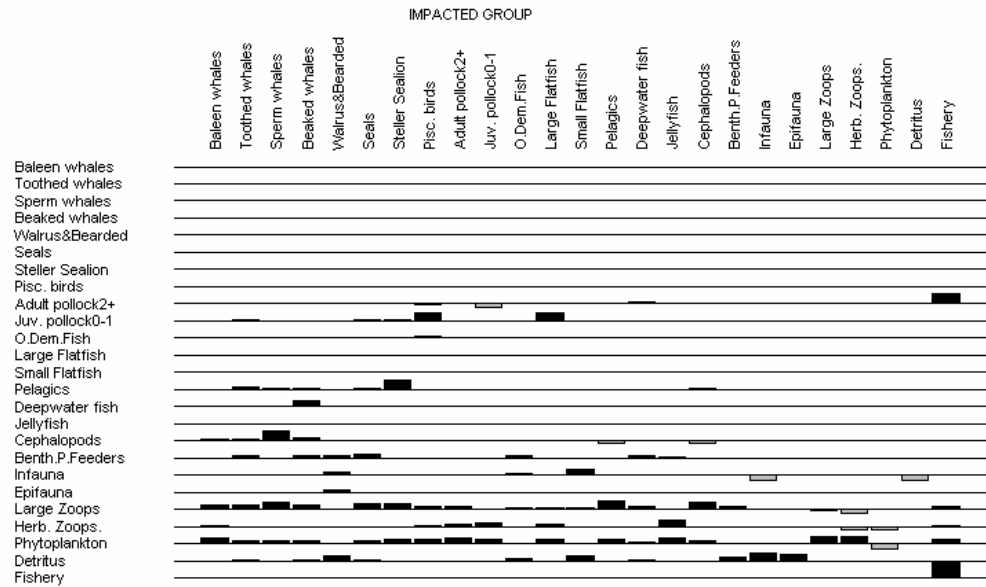

Fig. 7. The Leontif matrix showing mixed trophic impacts in the eastern Bering Sea ecosystem in the 1950s and 1980s models. Increasing the abundance of species on the Y-axis has positive (black bar), negative (grey bar) or no effect on species listed on the X-axis. Impacts are expressed as percent changes, and are relative and comparable between groups.

levels – most notably the birds and mammals. Greater primary production increases overall biomass.

Combining the information from predator and prey niche overlaps, and the mixed trophic impacts can generate hypotheses regarding changes in the structure of the ecosystem. These are tested later using Ecosim

Fisheries

We estimated the total catch in the eastern Bering Sea was $0.33 \text{ t}\cdot\text{km}^{-2}$ in the 1950s and $2.62 \text{ t}\cdot\text{km}^{-2}$ in the 1980s. Fisheries for whales, seals and fish were the sole exports from our modeled Bering Sea ecosystem.

The ratio of catch to primary production is a measure of gross efficiency of the fisheries. Higher ratios are expected for fisheries harvesting lower in the food chain. Lower values indicate a fishery that specializes on apex predators (Christensen and Pauly 1993) or mid-trophic level marine mammals such as baleen whales which have high consumption but low production rates. Most fisheries in the world have a weighted average ratio of 0.0002.

The ratio of catch to primary production in the eastern Bering Sea was 0.0002 in the 1950s and 0.0021 in the 1980s (Table 4). This 10-fold increase reflects the shift from primarily harvesting mostly mid-trophic level baleen whales and pelagic fish to catching primarily pollock, a mid-trophic level fish. The shift seen in the mean trophic level of the catch, which moved from 3.44 (1950s) to 3.30 (1980s), is a reflection of this shift from baleen whales to pollock. Although baleen whales consume mostly zooplankton, the slightly higher trophic level estimates of baleen whales relative to pollock is due to the presence of squid, a high trophic level species, in the baleen whale diet. Thus, the declining trend in trophic level of the catch is not due to a fishing down the food web effect that has been noted in other exploited marine ecosystems (Pauly et al. 1998b), but rather is due to a switch in targeting between two mid-trophic level species with slightly different diets. If trophic level of the catch in the Bering Sea is estimated using only fish and invertebrate catch and excluding the whaling of the 1950s and 1960s, there has actually been an increase in the estimated trophic level of the catch in the eastern Bering Sea from the 1950s to the present (Queirolo et al., 1995). The ratio of catch to primary production during the 1980s is also comparable to other shelf systems around the world where fishing concentrates on mid-trophic level fish species such as sardines and anchovies, as opposed to the 1950s Bering Sea system in which fishing was focused on mid-trophic level marine mammals.

Nearly 40% of net primary production in terrestrial systems is used to sustain agriculture, industry and other activities (Vitousek et al. 1986). Approximately 8% is required in aquatic systems (Pauly and Christensen 1995). However, this figure conceals a huge difference between coastal shelves where 25-35% of primary production is required to sustain 90% of the world's fisheries that is taken from coastal shelves, and the large open ocean which sustains relatively small fisheries. Notable exceptions are Pacific salmon which rely heavily on the

production of the open North Pacific Ocean, but are caught nearshore or in fresh water habitats. We estimated that the fisheries operating during the 1950s required 47% of the net primary production of the eastern Bering Sea, with most of it flowing through the whales that were removed by commercial whalers. The shifting emphasis from exploiting marine mammals (which have high consumption and low production rates) in the 1950s to catching fish (which have lower consumption and higher production rates) in the 1980s has lowered the need for primary production to 6.1%. About half of this primary production is required to sustain the pollock fishery.

Characterizing the Bering Sea Ecosystem

Table 5 contains many indices that characterize the eastern Bering Sea. All told, they indicate an ecosystem that according to some measures was more mature in the 1950s than in the 1980s. They also suggest a system in both time periods that is relatively resilient and resistant to perturbations. The indices allow the ecological characteristics of the eastern Bering Sea to be compared over time (1950s-1980s) and with other marine ecosystems.

Biomass pyramids are particularly useful for inter-system comparisons (Fig. 8). The volume of each compartment of a pyramid is proportional to its throughput, and the top angle of the pyramid is inversely proportional to the mean trophic

Table 8. Estimated net primary production required (PPR) to sustain fisheries for whales, seals and fish during the 1950s and 1980s. PPR is expressed as a percentage of total primary production available in the ecosystem.

	PPR (%)	
	1950s	1980s
Baleen whales	33.7	-
Sperm	9.7	-
Walrus & Bearded	1.0	0.7
Seals	2.2	0.4
Steller Sea lions	0.3	0.2
Adult pollock	0.0	2.8
O. demer. fish	0.0	0.7
Large flatfish	0.0	0.2
Small flatfish	0.3	0.6
Pelagics	0.1	0.2
Deepwater fish	0.0	0.1
Benth.P. feeders	0.0	0.1
Total	47.3	6.1

transfer efficiencies at trophic levels II-IV. The pyramids show how the energy-flows between groups are distributed between the different trophic levels.

Only the trophic pyramids for the 1950s model are shown in Fig. 8 because they are very similar to the 1980s pyramid. Both pyramids indicate that biomass and energy flow are distributed fairly well throughout system. They also show that apex predators at trophic level IV do not contribute much to the biomass of the eastern Bering Sea. Unlike biomass, flows (Fig. 8) are largely contained within the first three trophic levels of the system. The steep sided pyramid indicates that there is a lot of flow within these lower trophic levels.

The trophic pyramids (Fig. 8) and ecosystem indices (Tables 5 and 9) indicate that the eastern Bering Sea is a mature system compared to other shelf systems. However, they also show that in some ways the Bering Sea was less mature in the 1980s model compared to its state in the 1950s model.

The ratio of primary production to respiration reflects the maturity and development of an ecosystem. This ratio was close to 1.0 in the 1950s model (Table 5) and suggests a mature system where the amount of energy that was fixed in the ecosystem is balanced by the cost of maintenance. The value in the 1980s model was lower (0.74), indicating an ecosystem that is less mature. The lower value in the 1980s model primarily reflects our assumptions of lower biomass (and thus respiration) of benthic infauna, which provides a large proportion of the contribution to total system respiration, in the 1980s versus the 1950s models. Benthic infaunal surveys during the two periods used different survey methods and may not be comparable. Therefore, conclusions about system maturity based on our knowledge of benthic infauna biomass are possibly premature. Similarly, our conclusions about changes in system maturity based on the net amount of system production in the two periods and by the ratio of total biomass to energy throughput (Table 5), which are also based on the changes in respiration values due to our assumptions about benthic infauna biomass, should also be tempered by our uncertainty about these values in the two time periods.

Large values of net system production (the difference between total primary production and respiration) are expected in an immature ecosystem, and values close to zero are expected in mature ones. The estimated value is more than two times greater in the 1980s than the 1950s model, suggesting a loss in maturity. As noted above, the main reason for the higher value in the 1980s is due to the larger contribution of benthic infauna to the total respiration in the 1950s because of our assumption of higher benthic infauna biomass during that time period, which is a relatively uncertain assumption.

Another index that also suggests that the ecosystem was more mature in the 1950s is the ratio of biomass to throughput, which was slightly higher in the 1950s than in the 1980s (Table 5). This index expresses the proportion of biomass that can be supported by the available flow in a system; and will rise in value as a system matures. Again, the changes in this index reflect the changes in respiration and biomass in the system that are primarily due to our assumptions about benthic infauna biomass in the 1950s relative to the 1980s. Further assessment of the level of benthic infauna biomass during the present time may help us better understand the biomass dynamics of this group over time.

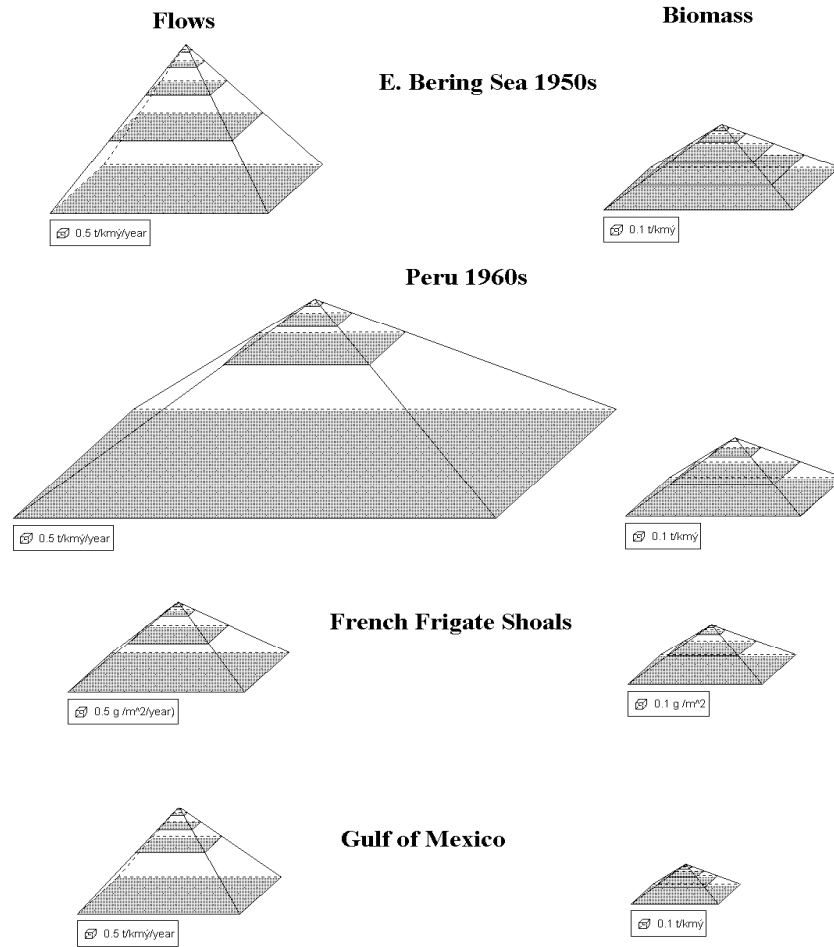

Fig. 8. Trophic pyramids representing the distribution of biomass and energy flow in four ecosystems. The pyramids are scaled so that the volume at each trophic level corresponds to the sum of all flows at that level. The top angles are inversely proportional to the transfer efficiency (acute angle = high efficiency).

One index that counters our conclusion about the loss of maturity is the ratio of primary production to total biomass (Table 5). In theory, biomass should accumulate in an immature system, and the ratio of primary production to biomass should decline as the system matures. Thus, we expected the value for the 1980s (4.94) to exceed the value for the 1950s (5.85). A declining ratio with increasing maturity would be expected under an assumption of similar primary production over the two periods. However, as noted in Appendix 1, we assumed lower primary production during the 1980s based on baleen isotope data from animals that were believed to feed primarily in the northern Bering Sea. But this assumption is not consistent with chlorophyll concentrations (another indicator of primary production) reported by Sugimoto and Tadokoro (1997). They indicate that primary production increased in the southeastern Bering Sea (the main area encompassed by our model) from the 1950s to the 1980s. A more complete understanding of the time trends in primary production in the North Pacific is needed. Furthermore, given the possibility for non-constant primary production

Table 9. Comparative statistics for the eastern Bering Sea models and other shelf models.

Ecosystems	Through -put	Catch PP	PP/B	B/T	Net syst. prod.	Omnivory Index	Ascen- dency	Cycling index	Path length
Yacutan	2362	0.0029	27.4	0.036	370	0.134	44.0	2.8	2.84
N. Gulf of Mexico	1790	0.0002	7.0	0.015	19	0.195	39.1	2.1	3.03
Venezuela (upwl.)	5309	0.0016	27.0	0.023	831	0.135	39.9	2.2	4.05
Brunei, SE Asia	1816	0.0008	28.6	0.018	300	0.201	29.4	16.3	2.80
Peru 70 (upwell.)	18800	0.0017	87.5	0.012	14709	0.169	38.1	8.7	3.63
Monterey	17513	0.0012	1.2	0.012	2208	0.324	66.2	4.4	3.63
Alaska Gyre	5946	-	38.1	0.015	407	0.103	42.3	-	2.03
BC Shelf	1237	-	21.1	0.180	4106	0.140	40.1	-	2.03
Bering S. 50's	6535	0.0002	5.9	0.050	-115	0.183	32.5	13.2	3.47
Bering S. 80's	5692	0.0021	4.9	0.050	-356	0.157	30.9	11.1	3.51

over time, we may need to derive new system maturity indices that do not rely on an assumption of constant primary production.

Another measure of ecosystem maturity is the connectance index, which expresses the actual number of links in a food web to the total number of possible links within the system (Table 5). Odum (1969, 1971) expected systems to shift from linear food chains to more complex web-like structures as they matured. Thus the 1950s model should have a higher connectance index than the 1980s model, but the two measures are virtually identical (Table 4). The connectance index may be useful for comparing two time periods but is not useful when comparing different ecosystems because it is affected by the number of boxes in a model. In most systems, the actual number of links is roughly proportional to the number of groups. Moreover, the connectance index is strongly determined by our level of diet details.

A more useful comparative index of system complexity is the 'system omnivory index' (Christensen 1995). This is the average omnivory index of all consumers weighted by the food intake. It measures the distribution of feeding interactions between trophic levels and can characterize the extent to which a system displays web like features. An individual group with an omnivory index of zero is a specialized feeder. High values indicate the group feeds on organisms at many different trophic levels. The omnivory index was 0.183 in the 1950s and 0.157 in the 1980s, suggesting that the eastern Bering Sea had more complex feeding interactions in the 1950s (Table 5). The lower value of this index in the 1980s model compared to the 1950s appears to be due a difference in our assumptions about the species composition and diet composition of benthic epifauna, whose diet in the 1980s model was assumed to have a higher proportion of detritus compared to the 1950s model. These omnivory estimates are consistent with those calculated from other ecosystems (Table 9) such as the Alaska Gyre and British Columbia Shelf (0.103-0.140) and the Bolinao and Virgin Islands coral reefs (0.182-0.227) which have a complex web structure (Aliño et al. 1993, and Opitz 1993).

'Total system throughput' is another descriptive statistic of an ecosystem. It is the sum of all flows from consumption, export, respiration and detritus, and represents the 'size' of the entire system in terms of its flow. Throughput was greater in the 1950s than in the 1980s model (6,534 versus 5,691 $t \cdot km^{-2} \cdot year^{-1}$), again primarily due to our assumption of a much higher infauna biomass in the 1950s than in the 1980s. It is noteworthy that both of values for the Bering Sea are greater than other studied shelf systems except for those areas with strong upwelling (Table 9). The fraction of the total system throughput that is recycled within the system was greater in the 1950s (13.2%) than in the 1980s (11.1%). With the exception of Brunei, this is more than three times greater than most other shelf systems listed in Table 9. The cycling index generally increases as systems mature (Christensen and Pauly 1998). This is an indication that the Bering Sea is more mature relative to other shelf ecosystems.

Ascendancy measures the average mutual information in a system and is scaled by throughput (Christensen and Pauly 1992a,b). Taking the difference between total system capacity and ascendancy is a measure of system overhead. Overhead provides limits on how much the ascendancy can increase and is a reflection of the systems 'strength in reserve' from which it can draw to meet unexpected perturbations (Ulanowicz 1986).

The eastern Bering Sea has a relatively low ascendancy when compared to other shelf systems. The system overhead is approximately 60-65% (with a capacity of 100% and an ascendancy of approximately 30-35%). This suggests that the Bering Sea ecosystem has significant 'strength in reserve'. Unfortunately it is unclear whether strength in reserve means resilience or resistance (i.e., the system may either be resistant to perturbations or it may be resilient and 'bounce back' quickly. It may even have a combination of both qualities).

Ecosim Model Results

We used Ecosim (Walters et. al. 1997) to investigate how fishing and a regime shift might have affected the eastern Bering Sea ecosystem. Ecosim is an extension of Ecopath that can run dynamic and equilibrium simulations. Equilibrium simulations dynamically adjust the ecosystem to compensate for changes in fishing mortality rates. The simulations calculate the equilibrium biomass for all species in the ecosystem over a range of fishing mortality that is directed at one or more species. Dynamic simulations can change fishing mortality rates, and can follow how the effect of fishing one group is propagated over time through all the others. Dynamic simulations can also simulate a regime shift by changing primary productivity and diet compositions. Assumptions about the available flow of food from one group to another can be evoked in both dynamic and equilibrium models to simulate 'top-down' or 'bottom-up' control

 Ecosim represents trophic ontogeny by linking adult and juvenile groups with a delay-differential model structure. It simultaneously accounts for the numbers and biomass of fish in each group by setting the rates of flow (recruits) from the juvenile to the adult boxes, and from the adult to the juvenile boxes (recruitment)

(Walters et al. 1997). We applied the two-pool delay differential model structure to pollock to capture the effects of trophic ontogeny, cannibalism, and distinct roles that adult and juvenile pollock play in the eastern Bering Sea. Model input parameters were based on Bakkala (1993) and FishBase 98 (Froese and Pauly 1998), and included: age at graduation to the adult box (2 years), the mean weight at graduation (0.052 Kilos, 20 cm fish), and the von Bertalanffy growth parameter ($k = 0.18 \text{ year}^{-1}$) (although it should be noted that more recent data specific to the eastern Bering Sea indicate weight of age-2 pollock is approximately 170g and the k parameter is around .228 (Wespestad et al. 1996)).

We applied *equilibrium simulations* to 5 species groups: baleen whales, sperm whales, pelagic fishes, pollock and large flatfish. The goal was to determine how the biomass of the 25 groups of species making up the Bering Sea might respond to changes in fishing pressure applied to each of these 5 species. We changed fishing pressure on baleen whales, sperm whales and pelagic fish in the 1950s model, and on pollock and large flatfish in the 1980s model.

We used *dynamic simulations* to gain insight into the mechanisms that might have changed the ecosystem from its 1950s state to its 1980s state. We also used the model to project the future consequences of changing some of the current fishing policies. The specific dynamic simulations we ran included:

- A regime shift simulation that altered the amount of primary production in the Bering Sea and shifted the diet of many predators from pelagic fishes to pollock. The simulation was initiated with the 1950s Ecopath model and run for 30 years. Results were compared with the observed status of the system as detailed in the 1980s model;
- A fishery simulation that explored whether human harvesting alone could explain the changes that occurred over 30 years;
- Three pollock fishing scenarios that explored how the ecosystem might change from its 1980s state if pollock fishing was changed. We considered what might happen to the Bering Sea if pollock fishing decreased the biomass of adult pollock by 50%. We also considered what might happen if pollock were overfished to the point that all the juvenile and adult pollock were removed. Finally, we considered how the Bering Sea ecosystem might look if pollock were not caught at all. All simulations were run for 30 years;
- Finally, we tried altering fishing mortality of pelagics and pollock (mid-trophic level groups) and estimating the amount of time required for the system to recovery. Fishing mortality (F) on these two groups was drastically increased (20 times fold) for a period of 10 years, then released back to the original F (Table 10). Simulations were run for 100 years using both the 1950s and 1980s Ecopath models for initiation.

Table 10. Original and increased fishing mortality rates (year⁻¹) used to assess system recovery time.

Fished group	1 x F		20 x F	
	1950	1980	1950	1980
Pelagics	0.0030	0.0150	0.0600	0.3000
Adult Pollock	0.0025	0.0700	0.0500	1.4000

Equilibrium Simulation Results

There are five sets of results for the equilibrium simulations, which we present as a series of graphs. The top left panels in each of the figures show the rate of exploitation (F) used in the 1950s or 1980s Ecopath models (marked by an arrow) and how altering F affects the numbers present (biomass) and the biomass caught (catch). F is the instantaneous fishing mortality rate (Ricker 1975) and is approximately equal to the fraction of the population that is removed each year over the range of values we considered (0.00 – 0.30 year⁻¹).

The exploitation rate of baleen whales in the 1950s model was about 12% per year (Fig. 9). Increasing F resulted in a short-term increase in numbers caught, but an ultimate decline in harvest as the population decreased to zero. Reducing F increased the whale population and ultimately resulted in a greater sustainable harvest.

Removing baleen whales from the 1950s Bering Sea model increases the toothed whales, sperm whales, walruses, bearded seals, sea lions and sea birds (Fig. 9). Reducing baleen whales increased zooplankton biomass (reduced predation) and increased their major competitors (pollock and cephalopods) which are fed upon by other marine mammals. Removing baleen whales had a positive effect on pollock but no discernable effect on pelagic fishes or seals (northern fur seals, harbor seals, larga seals, ribbon seals and ringed seals), which were the next most important competitors of baleen whales.

The model predicts that increases of baleen whales in the eastern Bering Sea could significantly reduce the abundance of pollock, cephalopods and deepwater fishes through direct competition for zooplankton.

Baleen Whales – 1950s

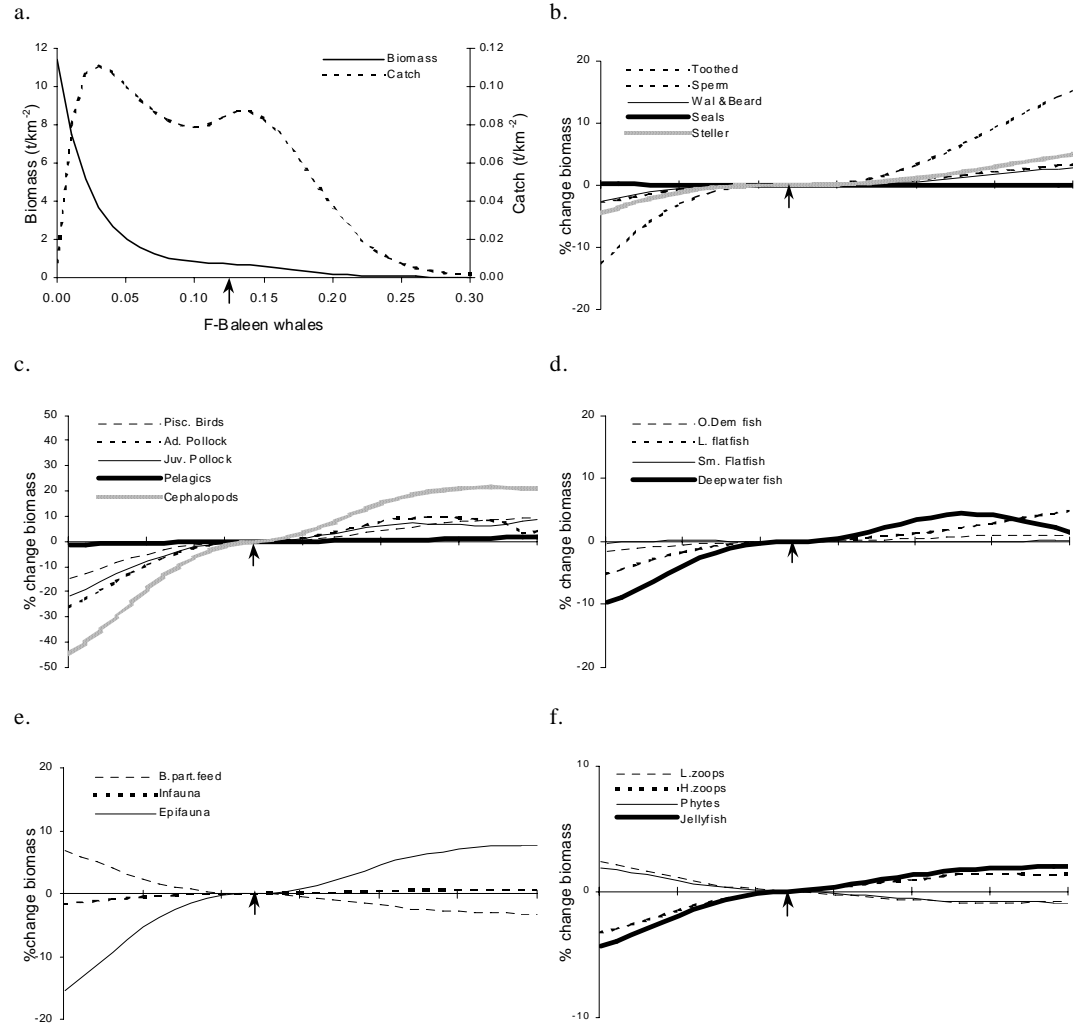

Fig. 9. Equilibrium biomass for Bering Sea species following changes to the fishing mortality of baleen whales in the 1950s model. Arrows mark the instantaneous rate of fishing (F; year⁻¹) during the 1950s. The top left panel shows changes in the biomass and catch of baleen whales under different levels of F. The other 5 panels show the relative change (%) that could occur to other species in the ecosystem to compensate for changes in the abundance of baleen whales.

Reducing sperm whale abundance in the 1950s model doubles the deepwater fish population, and increases the cephalopods (Fig. 10). These are the two major prey of sperm whales. Increasing sperm whale prey reduces Steller sea lions, sea birds, flatfish and pelagic fishes. Sperm whales presumably exert some control on cephalopods and deep water fishes, which affect other species in the food web.

Sperm Whales – 1950s

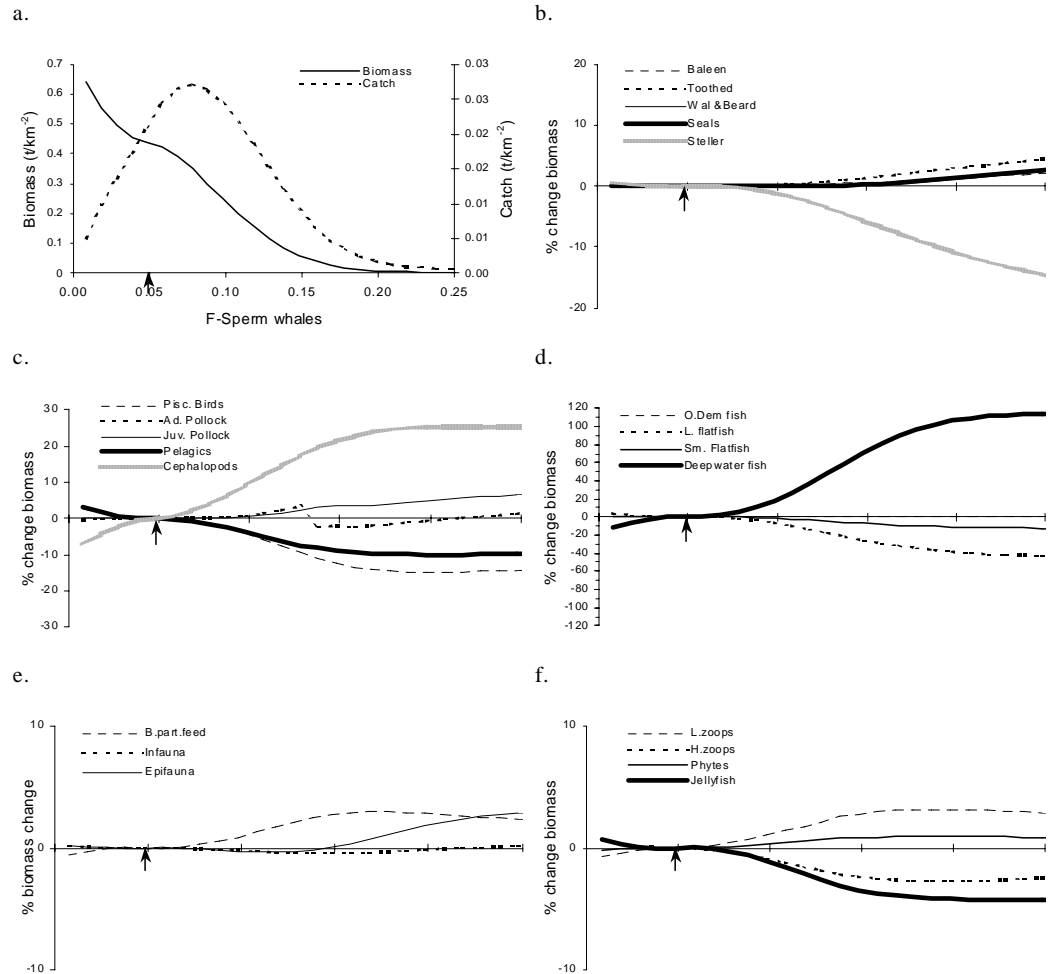

Fig. 10. Equilibrium biomass for Bering Sea species following changes to the fishing mortality of sperm whales in the 1950s model. Arrows mark the instantaneous rate of fishing (F; year⁻¹) during the 1950s. The top left panel shows changes in the biomass and catch of sperm whales under different levels of F. The other five panels show the relative change (%) that could occur to other species in the ecosystem to compensate for changes in the abundance of sperm whales.

Pelagic fish play a central role in the diet of many groups in the 1950s model and can have large system wide effects (Fig. 11). Reducing pelagic fish in this model caused significant declines of piscivorous birds, Steller sea lions and large flatfish that fed on them. The model predicts an 80% decline in sea lion abundance with a 50% decline in pelagic abundance. Food groups (zooplankton) and competitors (pollock) of pelagic fishes increased when they were released.

Some trophic cascade effects were observed, such as the increase in benthic particulate feeders due to an increase in food (zooplankton) and a decrease in predators (large flatfishes, walrus and bearded seals).

Pelagic Fish – 1950s

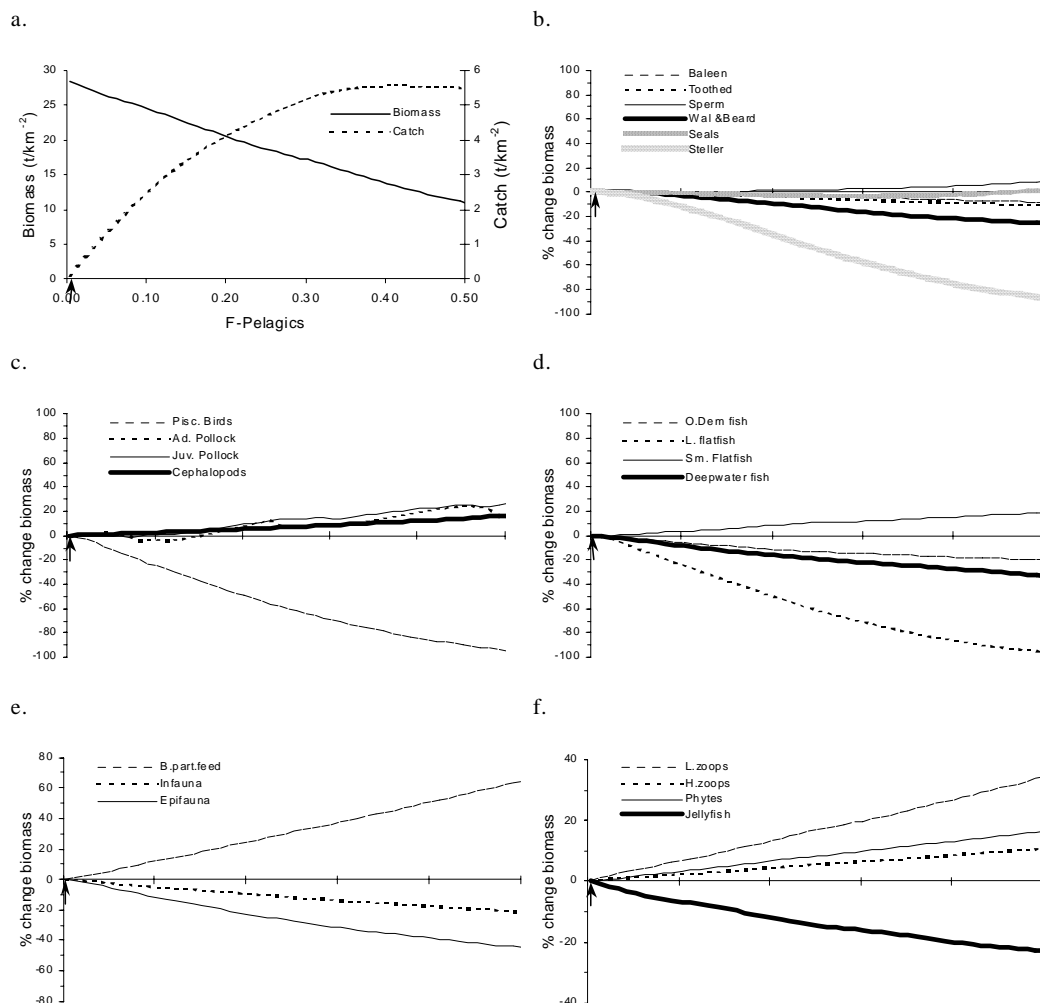

Fig. 11. Equilibrium biomass for Bering Sea species following changes to the fishing mortality of pelagic fishes in the 1950s model. Arrows mark the instantaneous rate of fishing (F; year⁻¹) during the 1950s. See Fig. 9 for further explanations.

Increasing fishing pressure on pollock has a very small, or minimal effect on the adult biomass in the 1980s model. This is apparently due to continuous replenishment from the juvenile population (which increases due to lower predation pressure – i.e., cannibalism). System wide effects are therefore minimal because the adult population does not change appreciably. The model predicts that seals, sea lions and piscivorous birds would increase if more adult pollock were caught because the abundance of juvenile pollock increases as cannibalism by adult pollock is reduced.

Pollock – 1980s

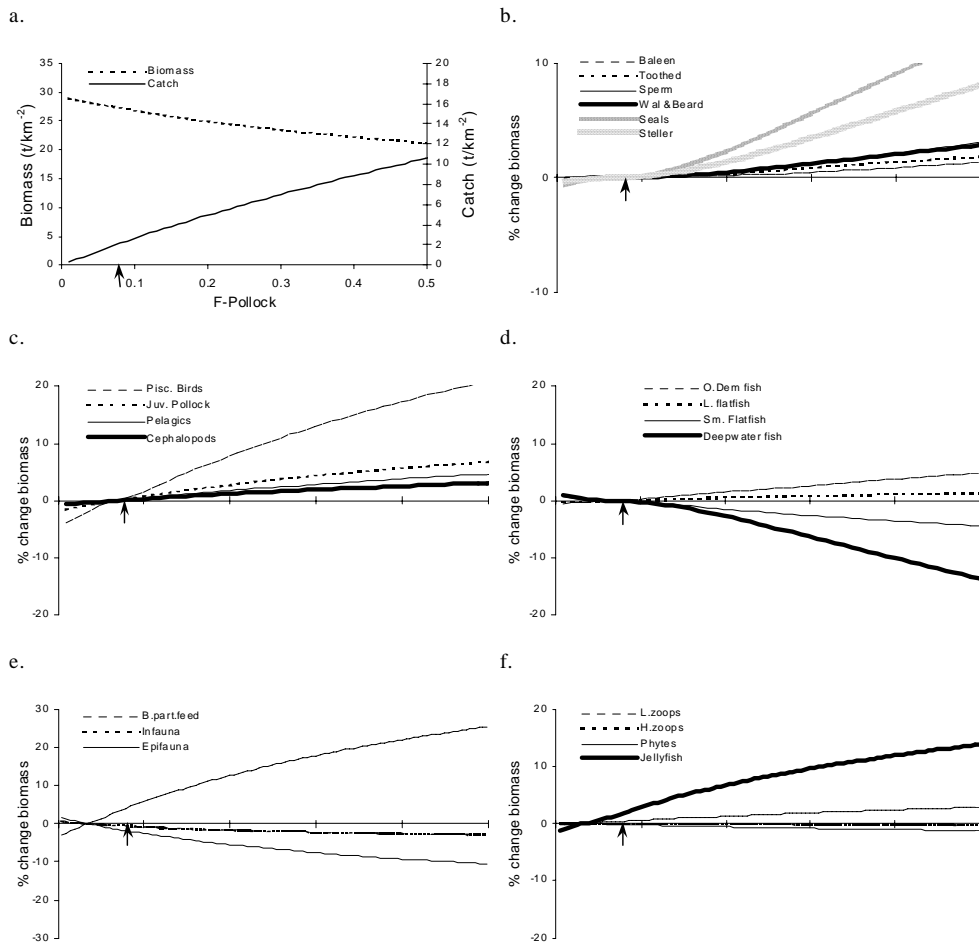

Fig. 12. Equilibrium biomass for Bering Sea species following changes to the fishing mortality of adult pollock in the 1980s model. Arrows mark the instantaneous rate of fishing (F; year⁻¹) during the 1980s. See Fig. 9 for further explanations.

Fishing large flatfish in the 1980s model increases Steller sea lions, seabirds and deepwater fish due to a competitive release of their food (pollock, small flatfish and other demersal fish). The two groups of species that do not benefit from increased fishing pressure on large flatfish are seals and crabs (Fig. 13). Cascading effects resulting from a decrease in large flatfishes include a decline in some pinnipeds (predators of flatfish), which further reduces predation on deepwater fish.

Large Flatfish –1980s

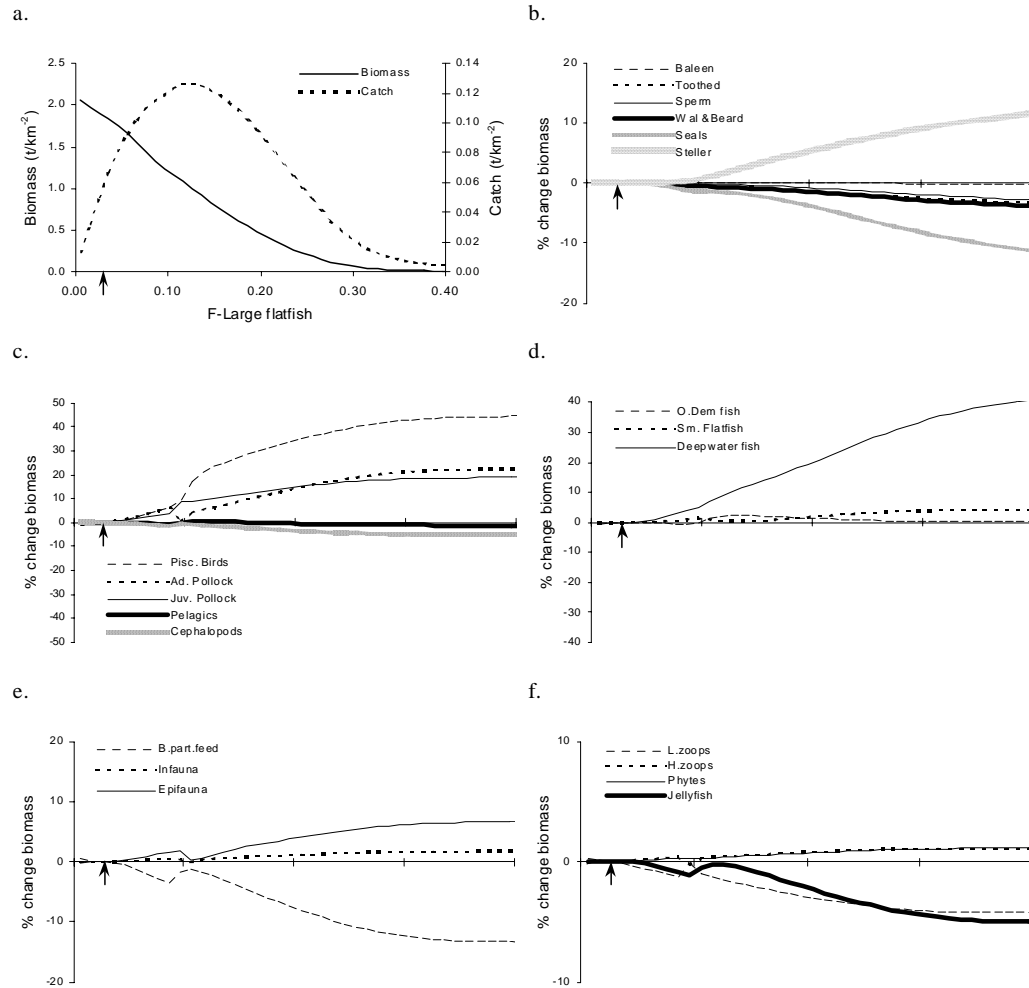

Fig. 13. Equilibrium biomass for Bering Sea species following changes to the fishing mortality of large flatfish in the 1980s model. Arrows mark the instantaneous rate of fishing (F ; year⁻¹) during the 1980s. See Fig. 9 for further explanations.

Dynamic Simulation Results

We ran five sets of dynamic simulations. The first began in 1955 and simulated the removal of reported catches of fish over a 30-year period. We calculated fishing mortality as $F = C/B$ (Table 11). With the exception of baleen and toothed whales, we assumed a simple linear change in the fishing mortality between the 1950s and 1980s (a 30-year period). For baleen and toothed whales, fishing mortality was held constant for the first 10 years, after which it declined linearly to zero by 1970.

Table 11. Estimated biomass, harvest and fishing mortality in the 1950s and 1980s.

	1950s			1980s		
	Biomass $t \cdot km^{-2} \cdot y^{-1}$ B	Harvest $t \cdot km^{-2} \cdot y^{-1}$ C	Fishing Mortality $F=C/B$	Biomass $t \cdot km^{-2} \cdot y^{-1}$ B	Harvest $t \cdot km^{-2} \cdot y^{-1}$ C	Fishing Mortality $F=C/B$
Baleen whales	0.696	0.084	0.121	0.394	0.000	0.000
Toothed whales	0.009	0.000	0.000	0.009	0.000	0.000
Sperm whale	0.439	0.021	0.048	0.208	0.000	0.000
Beaked whales	0.001	0.000	0.000	0.001	0.000	0.000
Walrus & bearded	0.054	0.006	0.111	0.074	0.004	0.054
Seals	0.106	0.005	0.047	0.066	0.001	0.015
Steller sea lion	0.029	0.001	0.034	0.019	0.001	0.053
Pisc. Birds	0.006	0.000	0.000	0.006	0.000	0.000
Adult pollock	5.500	0.014	0.003	27.451	1.895	0.069
Juv. Pollock	0.942	0.000	0.000	6.000	0.000	0.000
O. demer. Fish	8.957	0.001	0.000	3.904	0.128	0.033
Large flatfish	1.169	0.002	0.002	1.900	0.050	0.026
Small flatfish	8.530	0.105	0.012	9.161	0.211	0.023
Pelagics	28.869	0.083	0.003	13.644	0.212	0.016
Deepwater fish	1.011	0.001	0.001	0.407	0.007	0.017
Jellyfish	0.048	0.000	0.000	0.048	0.000	0.000
Cephalopods	3.500	0.000	0.000	3.500	0.000	0.000
Benth.P. feeders	29.000	0.010	0.000	5.800	0.108	0.019
Infauna	75.000	0.000	0.000	46.500	0.000	0.000
Epifauna	8.000	0.000	0.000	5.858	0.000	0.000
Large Zoops	44.000	0.000	0.000	44.000	0.000	0.000
Herb. Zoops	55.000	0.000	0.000	55.000	0.000	0.000
Phytoplankton	32.000	0.000	0.000	32.000	0.000	0.000
Discards	0.000	0.000	-	0.000	0.000	-
Detritus	-	-	-	0.000	0.000	-

Fishing (i.e., killing whales and catching fish) had little effect on the simulated ecosystem and failed to produce the large abundance of pollock observed in the 1980s. The only way to dramatically increase the amount of pollock and large flatfish in our simulated ecosystem was to abruptly change the amount of primary production in the Bering Sea.

Commercial Fishing Simulation

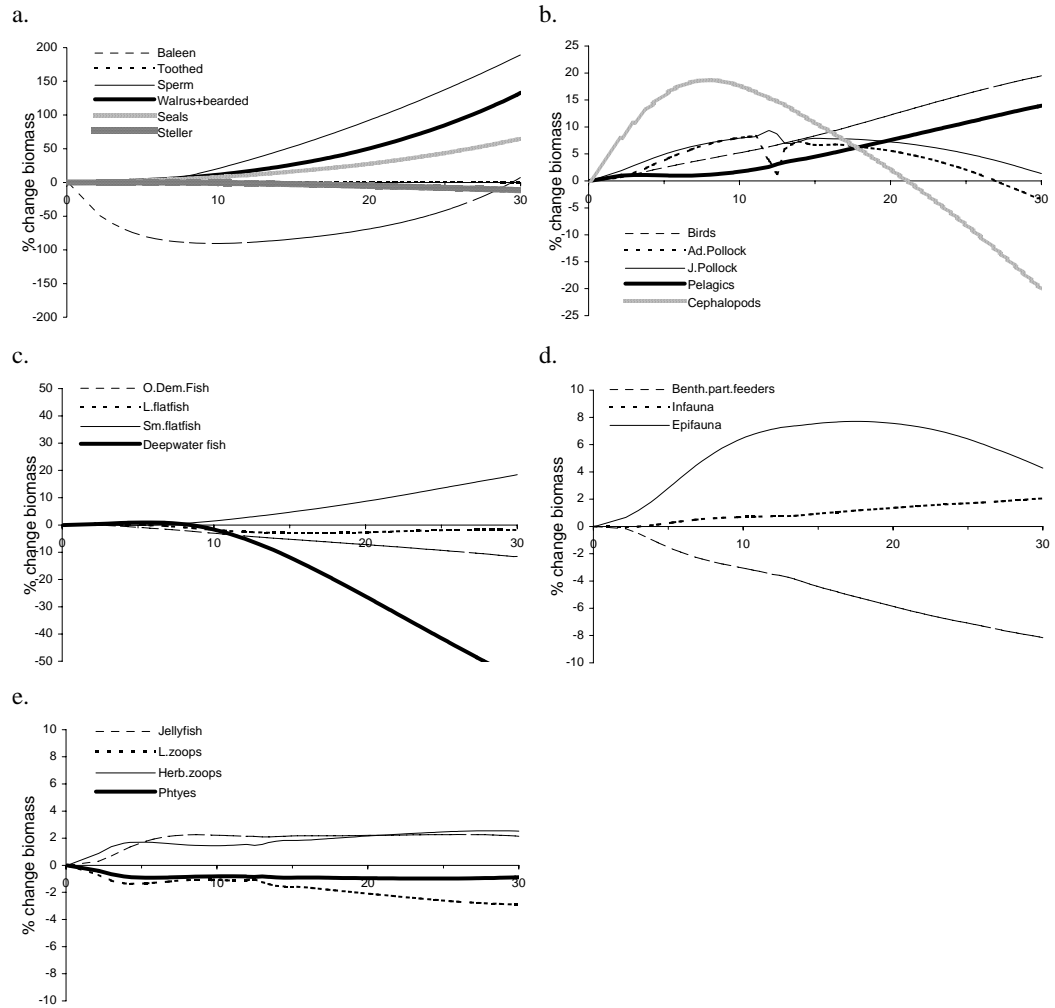

Figure 14. Dynamic simulation of the effects of commercial fishing from the 1950s to the 1980s. Note that some predators switched from eating pelagics to eating pollock, and that fishing mortality for Baleen whales was increased three-fold based on the EE values being roughly 3 times too high to balance the system during the 1950s.

Venrick et al. 1987 (see Fig. 3.16 in NRC 1996) estimate that the amount of chlorophyll (an index of phytoplankton production) in the central North Pacific almost doubled between the 1960s and the 1980s. The timing of this change in the 1970s is consistent with an hypothesized 'regime shift'. We therefore simulated an increase in primary productivity based on reported changes in the index of phytoplankton production detailed in Figure 3.16 of the NRC report (1996).

Adding more primary production to the 1950s ecosystem model increased the amounts of large zooplankton and cephalopods available as prey to other species (Fig. 15). Increases in their numbers led in turn to sharp cyclical increases and decreases in the abundance of fish and invertebrates, which dampened over time. Groups such as marine mammals do not have the capacity to rapidly turn the increased production into biomass and were not strongly affected by the sharp cycles in prey abundance. Curiously, only the Steller sea lions did not show an overall increase in numbers when primary production was increased.

The effects of simulating an increase in primary production were propagated through the food web. Pelagic fishes, benthic particulate feeders, sea birds and most mammals responded favorably to increased primary production (Fig. 15, Table 12). However, this simulation failed to completely move the system from its 1950s state to its 1980s state.

A change in primary production can explain more of the changes that occurred in the ecosystem than can the effects of commercial fishing. However, the regime shift would have had to affect more than just primary production to move the simulated ecosystem from our hypothesized 1950s state to our more certain understanding of the Bering Sea in the 1980s. Either something had to happen in concert with an increase in primary production to favor the survival of pollock and large flatfish, and disfavor the pelagics and benthic particulate feeders, or we may need to re-examine our evidence regarding the state of the Bering Sea in the 1950s, particularly with regard to pollock abundance and trophic connections to pollock.

Pollock appear to affect the abundance of crabs, cephalopods, pelagic fishes and other demersal fishes. In the absence of pollock (Fig. 16), these species increased as did marine mammals. The extinction of pollock could lead to the collapse of large flatfish in the model. However, this is contrary to evidence from stock assessments that showed Greenland turbot at its highest abundance in the 1970s prior to the large increase in pollock populations seen in the 1980s. Our models suggests the abundance of large flatfish is tied to the abundance of pollock. Similarly, piscivorous sea birds are dependent on juvenile pollock and would also face sharp declines if they did not switch to another major prey (Fig. 16).

It has been argued that the Steller sea lion population would increase if pollock fishing were curtailed. Presumably, there would be more pollock for Steller sea lions to eat. We simulated forward from the 1980s and explored this possibility by stopping all fishing of pollock (Fig. 17). Surprisingly, Steller sea lions and other marine mammals did not respond favorably to increases in the abundance of

adult pollock. Increases in adult pollock resulted in decreases in the abundance of juvenile pollock that piscivorous birds and many mammals fed upon.

Thus, paradoxically, the model suggests that one means to increase Steller sea lion populations may be to fish pollock harder. A positive increase in sea lion numbers was seen when pollock fishing was increased to cause a 50% reduction in adult pollock biomass (Fig. 18). Reducing adult pollock increased the abundance of juvenile pollock by reducing cannibalism. This in turn increased the abundance of crabs, birds, pelagic fish, other demersal fish and marine mammals.

1950s – Fishing & Regime Shift

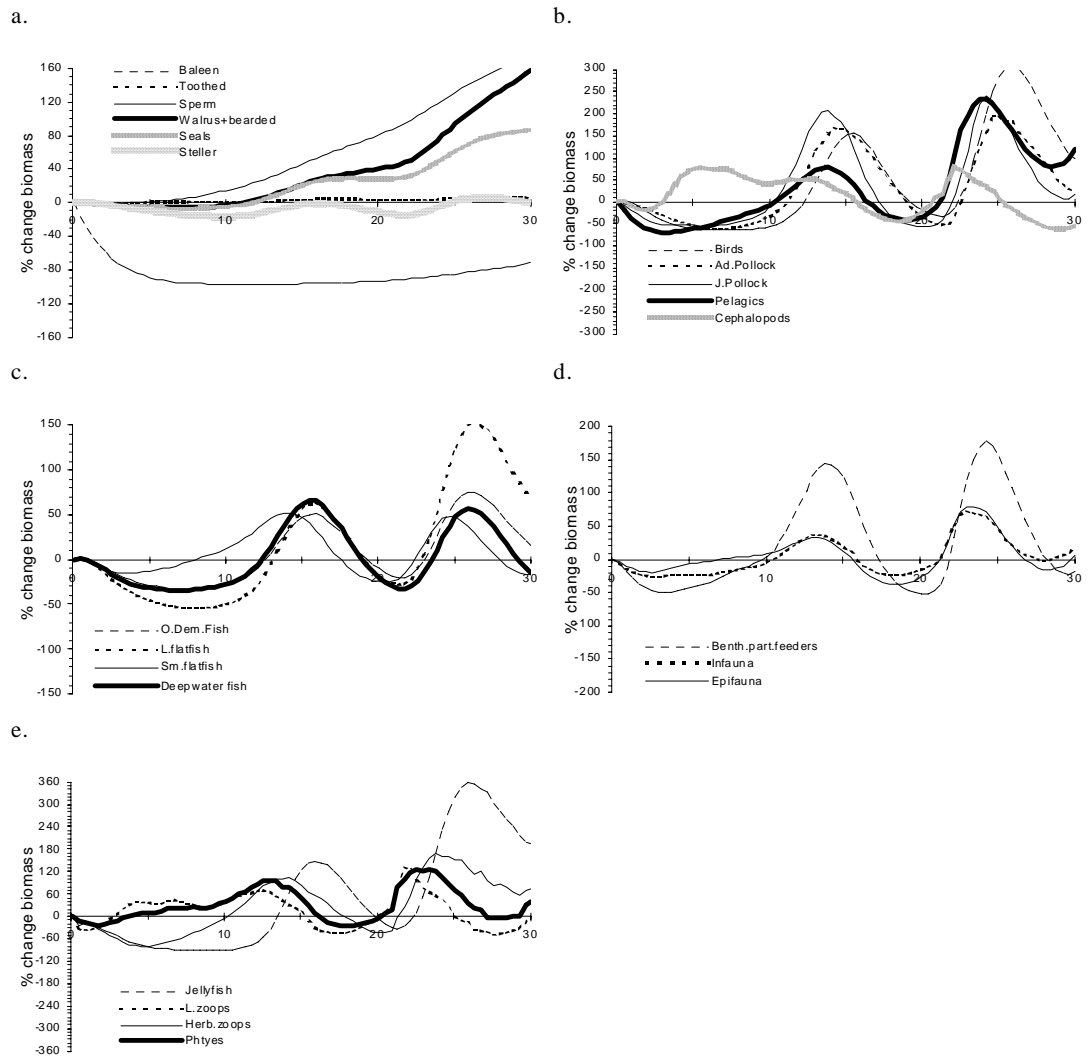

Figure 15. A dynamic simulation that began in the 1950s and incorporated realistic commercial catches (of fish and whales) and a regime shift (a cyclic increase in primary production). Diets of some predators were allowed to switch from pelagics to pollock, and the harvesting of baleen whales was increased by a factor of three.

Table 12. Results from dynamic simulations showing how historic fishing patterns would have changed the biomass of 25 groups of species between the 1950s model state and the 1980s, and how the biomass would have theoretically changed if a regime shift had increased primary production alone. The table shows the percent change observed in biomass between the 1950s and the 1980s, and the percent change observed when the model included historic fishing and the effects of a regime shift. Direction of change is indicated by + for increase, - for decrease and 0 for no appreciable change.

Functional group	Direction of Change			Change (%)		
	Observed	Simulated		Observed	Simulated	
		Fishing	Shift		Fishing	Shift
Baleen whales	-	+	-	-43	7	-71
Toothed whales	0	0	0	0	0	6
Sperm whales	-	+	+	-53	189	179
Beaked whales	0	0	0	0	-2	8
Walrus & bearded	+	+	+	37	133	158
Seals	-	+	+	-38	65	87
Steller sea lion	-	-	0	-34	-11	0
Pisc. Birds	0	+	+	0	19	98
Adult pollock	+	0	+	399	-3	23
Juv. pollock	+	0	+	537	1	18
O. demer. fish	-	-	+	-56	-12	16
Large flatfish	+	0	+	63	-2	67
Small flatfish	+	+	-	7	18	-16
Pelagics	-	+	+	-53	14	120
Deepwater fish	-	-	-	-60	-56	-16
Jellyfish	0	0	+	0	2	196
Cephalopods	0	-	-	0	-20	-55
Benth.P. feeders	-	-	-	-80	-8	-19
Infauna	-	0	+	-38	2	21
Epifauna	-	0	0	-27	4	6
Large zoops	0	0	0	0	-3	7
Herb. zoops	0	0	+	0	3	74
Phytoplankton	0	0	+	0	-1	39

Other retrospective analyses have also incorporated cannibalism into age structured models of pollock. They indicate that although cannibalism is significant and can explain some of the observed variation in juvenile survival rates, there is a large unexplained component of recruitment variation that is likely linked to environmental factors (Livingston and Methot 1998; Livingston and Jurado-Molina, in press). These environmental factors have the potential to shift adult pollock abundance to very high levels, as was observed with the 1978 pollock year class. The results of forward projections of the effect of fishing on the ecosystem using ECOSIM or age-structured models such as MSFOR, rely heavily on our assumptions about recruitment (Gislason 1993). Sensitivity of the results here need to be examined in that light. A long-term research goal should be to incorporate the results of process-oriented research on climatic links to recruitment variation into models which presently focus only on the predation links between species.

1980s – 100% Decrease of Adult Pollock

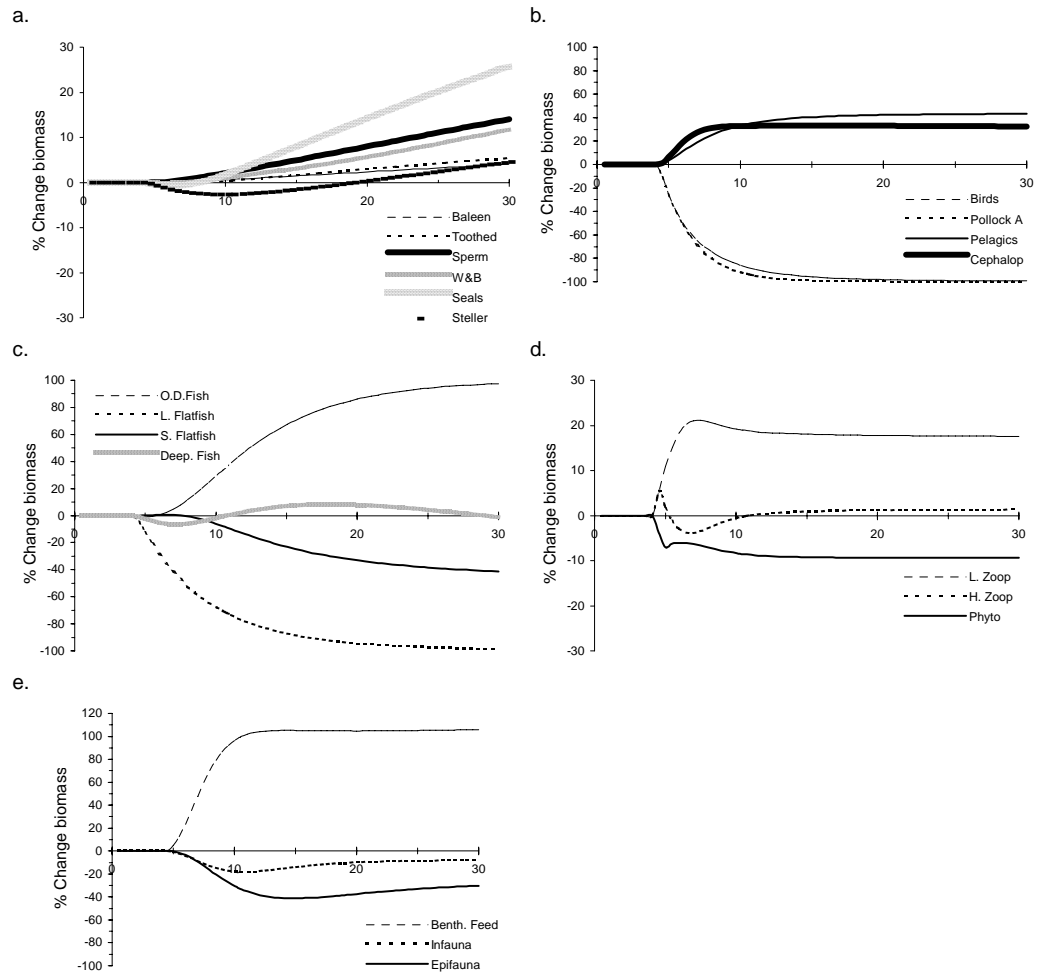

Fig. 16. A dynamic simulation showing the effect of removing adult pollock from the 1980s Bering Sea model ecosystem. The model predicts the decline of pollock would also lead to the decline of seabirds because they can no longer feed on juvenile pollock. Whether this would in fact happen depends upon whether seabirds would switch their diet to the growing pelagic fish populations. The release of food (zooplankton) allows pelagics and benthic particulate feeders to increase, as well as their predators who benefit from reduced predation from a common predator (large flatfish).

1980s – 0% Decrease of Adult Pollock

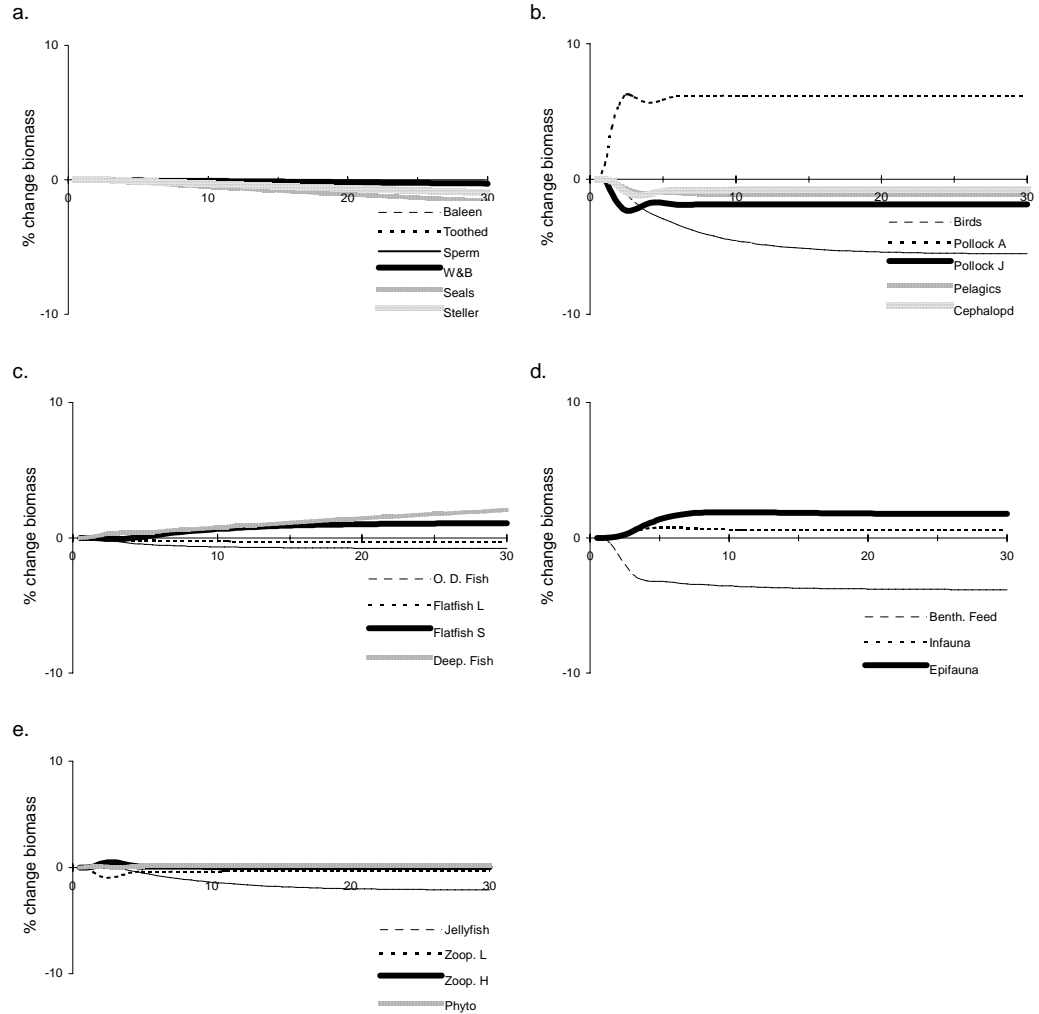

Fig. 17. A dynamic simulation showing the effect of stopping commercial fishing for adult pollock in the 1980s Bering Sea model ecosystem. Catching no adult pollock results in a larger adult population and a smaller juvenile pollock population. The majority of other groups in the Bering Sea are largely unaffected by a reduction in pollock fishing.

1980s – 50% Decrease of Adult Pollock

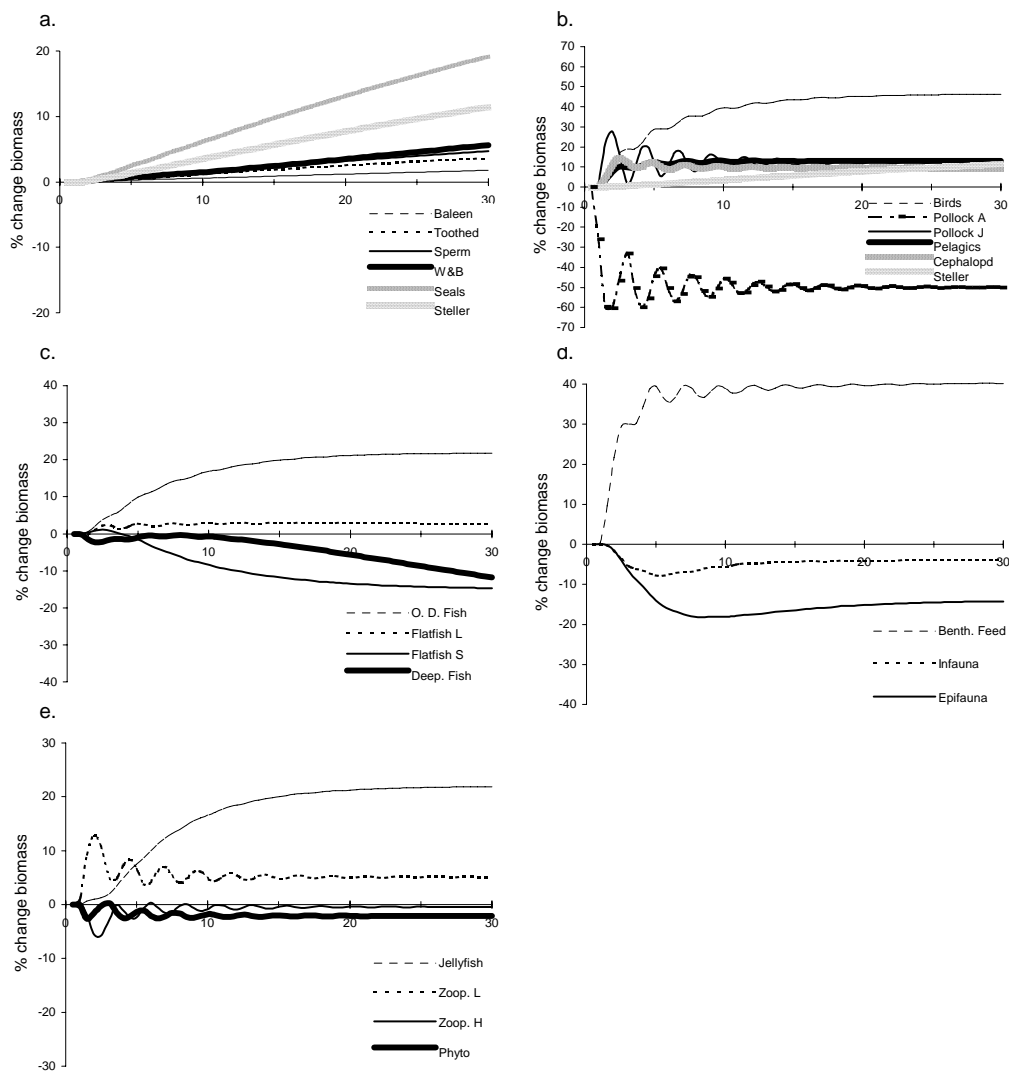

Fig. 18. A dynamic simulation showing the effect on the 1980s Bering Sea model ecosystem of decreasing the biomass of adult pollock by 50%. The model predicts an increase in the prey of adult pollock (large zooplankton and juvenile pollock), an increase in competitors (mainly the fast growing groups – jelly fish, benthic feeders, pelagics and sea birds). Marine mammals show a positive change, but are limited by their inherent low productivity.

System Recovery Time

Increasing the fishing mortality by 20-fold on pelagics and pollock for 10 years before releasing it back to its original level affected all trophic levels in both the 1950s and 1980s models. Species that took the longest to return to their original abundance were those at high trophic levels (Table 13).

Fishing pollock heavily in the 1950s would not have affected many species because we assumed that overall pollock abundance was low and that no species were eating substantial amounts of pollock at that time. Pelagic fish were important in both time periods but seem to be more critical in the 1980s than in the 1950s given that more species were impacted for longer periods by the lower pelagic fish abundance in the 1980s. This may reflect the relatively low biomass of pelagics in the 1980s and the greater amount of time required for small populations of marine mammals to rebuild.

Table 13. The last species to recover from an increase in fishing pressure on pelagics or pollock. Fishing mortality (F year⁻¹) on the two mid-trophic level groups was drastically increased (20 times fold) for a period of 10 years, then released back to the original F (see Table 10). We ran four simulations for 100 years initiated with the 1950s and 1980s Ecopath models. The table shows the number of years it took for the slowest species to recover and the percentage of recovery achieved in that time, or the percentage of recovery following 100 years of simulation.

Model	Grouped Fished	Species Affected	Recovery	
			years	%
1950s	Pelagics	Steller sea lion	100	98
1950s	Adult Pollock	Adult pollock	23	100
1980s	Pelagics	Steller sea lion	100	95
		Deepwater fish	100	97
		Seals	100	101
		Sperm Whales	100	101
1980s	Adult Pollock	Steller sea lion	100	101
		Deepwater fish	100	98
		Seals	100	101
		Sperm whales	100	100
		Beaked whales	100	99

Discussion of Simulation Results

Ecosim tracked trophic interactions over 30-100 years of simulation. It showed how altering the abundance of one species can affect others, and how the system as a whole might respond. It is therefore a useful tool for understanding what role commercial fisheries may play in restructuring the Bering Sea.

All of our simulations showed that, if our assumptions about the state of the Bering Sea in the 1950s are accurate, trophic interactions alone cannot explain the magnitude of changes that occurred in the biomass of major groups in the eastern Bering Sea between the 1950s and the 1980s. This conclusion about the Bering Sea differs from that drawn for the Gulf of Thailand, where fishing rates alone could move the system from one state to another (1960s-1980s: before and after the development of trawl fisheries, Christensen 1998). These findings beg the question of whether tropical marine ecosystems are more influenced by trophic interactions than environmental events compared to northern marine ecosystems.

Our models suggest that removing historic levels of commercial fish catches from the Bering Sea had little effect on the dynamics of the system. A regime shift that affected the base of the food web (primary production) would have had a pronounced effect on the abundance of many species, but is also insufficient by itself to explain the totality of changes that occurred. Some other factor would have had to be at play to favor the survival of certain species (such as pollock) over others (such as crabs). That factor may be physical oceanographic changes in water temperature and ocean currents that increase survival rates of certain species such as pollock and other groundfish.

Strong year classes of groundfish were more frequent in the eastern Bering Sea and Gulf of Alaska after 1976, and are linked to large scale physical forcing factors (Hollowed et al. 1998). Similarly, Quinn and Niebauer (1995) linked pollock survival to both environmental and biological factors such as predation. An age-structured model of walleye pollock that includes predation also provides evidence of higher juvenile pollock survival in the years after 1978, in early life history stages before predation mortality occurs (Livingston and Methot 1998). Thus, there is evidence of climate-related shifts in survival rates of pollock beginning in the late 1970s.

Another factor influencing our inability to project forward from the 1950s model to attain a semblance of the 1980s Bering Sea ecosystem, is our uncertainty over the state of the Bering Sea in the 1950s. We lacked quantitative data on many species in the 1950s and assumed that they had the same abundance as was observed in the 1980s. For other species, we used data from Soviet bottom trawl surveys in the 1950s that suggested low pollock abundance relative to the present. However, there are large uncertainties in comparing those historical catch rates to present day catch rates due to the different gear used by the Soviets in the early days compared to the gear presently used in U.S surveys. Anecdotal evidence in reports of these Soviet fisheries investigations indicates that our assumptions about low pollock biomass and little predation on pollock by other species may be inaccurate. Shuntov (1972) reported that during their

investigations from 1957-1964, walleye pollock was one of the most common Bering Sea fishes and was a staple food of large flatfish as well as other fishes. However, stomach contents of Steller sea lions shot in the Gulf of Alaska show a shift in diet from largely pelagic fishes in the 1950s to pollock and flatfish in the 1970s and 1980s (Alverson 1992). Future work to improve the 1950s model should include testing alternative assumptions about the dominance of pollock during that time period.

Conclusions

One of the questions we posed at the outset of this study was whether the niche once occupied by whales is now occupied by pollock. We took two approaches. One was to remove pollock from the 1980s ecosystem to see if whale populations would rebuild. The other was to remove the whales from the 1950s ecosystem to see if pollock would explode. Neither approach produced conclusive results about the role that whaling played in increasing pollock biomass. The most we can say is that removing whales would have had a positive effect on pollock by reducing competition for food. However, whaling alone is insufficient to explain the 400% increase in adult pollock biomass that may have occurred between the 1950s and the 1980s.

Although we did not focus on the relative importance of pelagics and pollock in the eastern Bering Sea ecosystem, there appears to have been a switch between dominance of these two mid-trophic level species. This switch between the 1950s and 1980s merits further investigation.

The magnitude of changes in the biomass of the major groups in the eastern Bering Sea cannot be explained solely through trophic interactions. The key to explaining the large-scale dynamics of the eastern Bering Sea may well be an environmental shift that favors one complex of species over another. Our models suggest that oceanographic factors such as changes in water temperature or ocean currents must have been at play and may be an important factor in affecting ecosystem production and recruitment variation in species. It is intriguing to think that the Bering Sea may have two alternative states, containing two suites of dominant species, and that the transition between the two may be very rapid. Steele and Henderson (1984) and Spencer and Collie (1996) describe models that show the possibility of such rapid transitions.

One of the more interesting predictions of the ecosystem model is that stopping pollock fishing might negatively affect many of the top predators in the Bering Sea. The model indicates that top predators might realize a greater benefit if pollock were fished at high levels or if large flatfish such as arrowtooth flounder were fished at higher rates due to the competitive release of prey. We are not advocating such changes in fishing, but rather are pointing out that the system, when viewed at this aggregated level, may not respond in the way that many

people might have predicted without the assistance of a quantitative, holistic model.

We recognize that our assumptions about recruitment influence our conclusions about the effects of fishing on the system, and that species likely respond differently to climate forcing at the inter-annual and inter-decadal time scales. Although we attempted to capture recruitment variability due to predation, the climate related variability is large and could show that the system may not respond in a way that our predation model indicates. Thus, future ecosystem simulations should explicitly consider the sensitivity of model results to different assumptions about climate effects on recruitment.

Our models do not yet capture the spatial aspects of foraging and fishing removals that may be important in explaining marine mammal and fishery interactions (Trites et al., in press). More research is needed to characterize the foraging ecology of Steller sea lions and the seasonal changes in the distribution and abundance of pollock and sea lions relative to fishing, to fully evaluate the effect of fishing on sea lions. Further scrutiny should also be given to our assumption of cannibalism because of the fundamental role it appears to play in structuring the Bering Sea ecosystem.

While some indices indicated that the 1950s ecosystem, as we modeled it, was at a more mature state than in the 1980s, it cannot be said that the 1980s system was unhealthy. Rather, the indices pointed out the large role that benthic infauna and epifauna play in determining ecosystem-level estimates of maturity and highlighted our uncertainty about these parts of the eastern Bering Sea ecosystem. There is still a great deal of uncertainty about the state of the Bering Sea in the 1950s that may require further analysis and model experiments.

Our models of the eastern Bering Sea ecosystem are an important first step in developing an ecosystem framework that will guide fisheries managers. The obvious next steps are to complete validation of these models and to develop a spatially explicit model that can track the movements of species from one area of the Bering Sea to another. Another critical need is to incorporate habitat and environmental data, or perhaps to link Ecopath and Ecosim to climate models (Trites et al., in press). A fuller understanding of the eastern Bering Sea is only likely to come when biological models are ultimately linked to physical models.

Literature Cited

- Alaska Department of Fish and Game. 1994. Annual management report for the shellfish fisheries of the westward region, 1992. Regional Information Report No. 4K94-9. Alaska Department of Fish and Game, Commercial Fisheries Management and Development Division. 211 Mission Road, Kodiak, AK 99615.
- Aliño, P.M., L.T. McManus, J.W. McManus, C.L. Nañola, Jr., M.D. Forbes, G.C. Tronno, Jr. And G.S. Jacinto. 1993. Initial parameters estimations of a coral reef flat ecosystem in Bolinao, Pangasinan, Northwestern Phillipines, p. 252-258. *In* V. Christensen and D. Pauly (eds.) Trophic models of aquatic ecosystems. ICLARM Conf. Proc. 26, 390 p.
- Allen, K.R. 1971. Relation between production and biomass. *J. Fish. Res. Bd. Canada.* 28:1573-1581.
- Alverson, D.L. 1992. Commercial fisheries and the Steller sea lion (*Eumetopias jubatus*): the conflict arena. *Rev. Aquat. Sci.* 6:203-256.
- Alverson, D. L. and Hughes, S.E. 1995. Bycatch: from emotion to effective natural resource management. p. 13-29. *In* Solving Bycatch: Considerations for today and tomorrow. Alaska Sea Grant College Program Report No. 96-03, University of Alaska Fairbanks.
- Arai, M.N. 1997. A Functional Biology of Scyphozoa. Chapman & Hall, London. 316 p.
- Baker, C.S. and L.M. Herman 1987. Alternative population estimates of humpback whales (*Megaptera novaeangliae*) in Hawaiian waters. *Can J. Zool.* 65: 2818-2821.
- Bakkala, R.G. 1993. Structure and historical changes in the groundfish complex of the eastern Bering Sea. U.S. Department of Commerce, NOAA Tech. Rep. NMFS 114. 91 pp.
- Banse, K. and S. Mosher. 1980. Adult body mass and annual production/biomass relationships of field populations. *Ecol. Monogr.* 50:355-379.
- Barnes, R.D. 1980. Invertebrate Zoology. Saunders College, Philadelphia. 1089 p.
- Barrett-Lennard, L.G., K. Heise, E.Saulitis, G. Ellis, C. Matkin. 1995. The impact of killer whale predation on Steller sea lion populations in British Columbia and Alaska. University of British Columbia, Fisheries Centre, 2204 Main Mall, Vancouver, B.C. V6T 1Z4.

- Berzin, A.A. 1959. On the feeding of sperm whales (*Physeter catodon*) in the Bering Sea. [in Russian] Izv. Tikhookean. Nauchno-Issled. Inst. Rybn. Khoz. Okeanogr. (TINRO) 47: 161-165. [translation available from National Marine Mammal Laboratory, NMFS, Seattle WA).
- Berzin, A.A., and A.A. Rovnin. 1966. The distribution and migrations of whales in the notheastern part of the Pacific, Chukchee and Bering Seas. Pages 103-136, *In*. K.I. Panin (ed.), Soviet research on marine mammals of the Far East. U.S. Dep. Interior Bureau of Commercial Fisheries, Seattle, WA.
- Bigg, M.A. 1990. Migration of northern fur seal (*Callorhinus ursinus*), on St. Paul Island, Alaska. Fish Bull. 84: 383-394.
- Bonfil, R., G. Munro, U.R. Sumaila, H. Valtysson, M. Wright, T. Pitcher, D. Preikshot, N. Haggan, and D. Pauly (eds) 1998. Distant water fleets: an ecological, economic and social assessment. Fisheries Centre Research Reports 6(6), 111pp.
- Braham, H.W. 1991. Endangered whales: status update. A Report on the 5-year status of stocks review under the 1978 amendments to the U.S. Endangered Species Act. NMFS Unpublished Report.
- Braham, H.W. 1984. The bowhead whale, *Balaena mysticetus*. Mar. Fish. rev. 46: 45-53.
- Braham, H.W., J.J. Burns, G.A. Fedoseev, and B.D. Krogman. 1984. Habitat partitioning by ice-associated pinnipeds: Distribution and density of seals and walruses in the Bering Sea, April 1976. *In* F.H. Fay and G.A. Fedoseev (eds.). Soviet-American cooperative research on marine mammals. Vol. 1: Pinnipeds, p. 25-47. U.S. Dep. Commer., NOAA Tech. Rep. NMFS-12.
- Brethes, J-C., B. Parent, and J. Pellerin. 1994. Enzymatic activity as an index of trophic resource utilization by the snow crab *Chionoecetes opilio* (*O. Fabricius*). J. Crust. Biol. 14:220-225.
- Brodeur, R.D. and P.A. Livingston, 1988. Food habits and diet overlap of various eastern Bering Sea fishes. NOAA Tech. Memo. NMFS F/NWC-127, 76p.
- Bukhtiyarov, Y.A., Frost, K.J. and Lowry, L.F. 1984. New information on foods of the spotted seal, *Phoca largha*, in the Bering Sea in spring. p. 55-59. *In* F.H. Fay and G.A. Fedoseev (eds.). Soviet-American cooperative research on marine mammals. Vol. 1: Pinnipeds, U.S. Dep. Commer., NOAA Technical Report NMFS 12.
- Burns, J.J. 1973. Marine mammal report. Alaska Dept. Fish and Game, Pittman-Robertson Project Rep. W-17-3, W-17-4, and W-17-5.
- Burns, J.J. 1981a. Bearded seal - *Erignathus barbatus* Erxleben, 1777. p. 145-170, *In* S.H. Ridgway and R.J. Harrison (eds.), handbook of Marine Mammals. vol. 2, Seals. Academic Press, New York.

- Burns, J.J. 1981b. Ribbon seal - *Phoca fasciata*. p. 89-109. *In* S.H. Ridgway and R.J. Harrison (eds.), Handbook of Marine Mammals. vol. 2. Seals. Academic Press, New York.
- Burns, J.J. 1986. Ice seals. p. 216-229. *In* D. Haley (ed.), Marine mammals of eastern North Pacific and arctic waters, 2nd ed., rev. Pacific Search Press, Seattle, WA.
- Calambokidis, J., G.H. Steiger, J.M. Straley, T. Quinn, J. Barlow, L.M. Herman, S. Cerchio, D.R. Salden, M. Yamaguchi, F. Sato, J.R. Urban, J. Jacobson, O.Von Zeigesar, K.C. Balcomb, C.M Gabriele, M.E. Dahlheim, N. Higashi, J.K.B. Ford, Y. Miayfumi, P. Ladron de Guevara, S.A. Mizroch, L. Schlender, and K. Rasmussen. 1997. Population abundance and structure of humpback whales in the North Pacific basin. Draft Final Contract Report 50ABNF500223 to Southwest Fisheries Science Center, P.O. Box 271, La Jolla, CA 92038. 67 p.
- Calkins, D.G. and E. Goodwin. 1988. Investigation of the declining sea lion population in the Gulf of Alaska. Unpubl. Rep., Alaska Dep. Fish and Game, 333 Raspberry Road, Anchorage, AK 99518. 76 p.
- Christensen, V. 1995. Ecosystem maturity - towards quantification. *Ecol. Modelling* 77:3-32.
- Christensen, V. 1998. Fishery induced changes in a marine ecosystem: insight from models of the Gulf of Thailand. *Journal of Fish Biology* 53 (suppl. A): 128-142.
- Christensen, V. and D. Pauly. 1992a. ECOPATH II - a software for balancing steady-state models and calculating network characteristics. *Ecol. Modelling* 61:169-185.
- Christensen, V. and D. Pauly. 1992b. A guide to the ECOPATH II program (version 2.1). ICLARM Software 6, 72 p.
- Christensen, V. and D. Pauly (Editors). 1993. Trophic models of aquatic ecosystems. ICLARM Conference Proceedings No. 26, 390 p.
- Christensen, V. and D. Pauly. 1995. Fish production, catches and the carrying capacity of the world oceans. *NAGA, the ICLARM Q.* 18(3): 34-40.
- Christensen, V and D. Pauly. 1998. Changes in models of aquatic ecosystems approaching carrying capacity. *Ecological Applications* 8: S104-S109.
- Climo, L. 1993. The status of cliff-nesting seabirds at St. Paul, Island Alaska in 1992. U.S. Fish and Wildl. Serv. Rep., AMNWR 93/15. Homer, Alas. 53p.
- Cooney, R.T. 1981. Bering Sea zooplankton and micronekton communities with emphasis on annual production. p. 947-974. *In* Hood, D.W. and J.A. Calder (eds.) The eastern Bering Sea shelf: Oceanography and Resources, Vol. II. Univ. Wash. Press, Seattle. 1339 p.

- Dagg, M.J., J. Vidal, T.E. Whitley, R.L. Iverson, and J.J. Goering. 1982. The feeding, respiration, and excretion of zooplankton in the Bering Sea during a spring bloom. *Deep-Sea Res.* 29:45-63.
- Dalheim, M., A. York, J. Waite, and C. Goebel-Diaz. 1992. Abundance and distribution of harbor porpoise (*Phocoena phocoena*) in Southeast Alaska, Cook Inlet and Bristol Bay. Annual report to the MMPA Assessment Program. Office of Protected resources, NMFS, NOAA, 1335 East-West Highway, Silver Spring, MD 20910.
- Dalsgaard, J. and D. Pauly 1997. Preliminary mass-balance model of Prince William Sound, Alaska, for the pre-spill period, 1980-1989. Fisheries Centre Research Reports 5(2), 84 pp.
- Diamond, J. 1997. *Guns, Germs and Steel: the Fates of Human Societies*. Norton, NY, USA, 48pp.
- Dragoo, B.K. and K. Sundseth. 1993. The status of northern fulmars, kittiwakes, and murrelets at St. George Island, Alaska. U.S. Fish and Wildl. Serv. Rep., AMNWR 93/10. Homer, Alaska. 92 p.
- Dwyer, D. A., K. M. Bailey, and P.A. Livingston. 1987. Feeding habits and daily ration of walleye pollock (*Theragra chalcogramma*) in the eastern Bering Sea, with special reference to cannibalism. *Can. J. Fish. Aquat. Sci.* 44: 1972-1984.
- English, T.S. 1979. Acoustic assessments of zooplankton and juvenile pollock in the southeastern Bering Sea. PROBES Prog. Rep. Vol. I. Dep. Oceanogr. Univ. of Washington, Seattle.
- Evans, P.G.H. 1987. *The natural history of whales and dolphins*. Facts on File Publications, New York. 343p.
- Evans, S. 1984. Energy budgets and predation impact of dominant epibenthic carnivores on a shallow soft bottom community at the Swedish west coast. *Estuar. Coast. Shelf Sci.*:18:651-672.
- Fay, F.H., L.L. Eberhardt, B.P. Kelly, J.J. Burns and L.T. Quakenbush. 1997. Status of the Pacific walrus population, 1950-1989. *Mar. Mamm. Sci.* 13: 537-565.
- Feder, H. 1978. Survey of the epifaunal invertebrates of the southeastern Bering Sea. p. 1-126 *In* Environmental Assessment of the Alaskan Continental Shelf, Annual Reports vol. 4. U.S. Dep. Commer., Natl. Oceanic Atmos. Admin., Environ. Res. Lab. Boulder, CO.
- Feder, H.M. and S.C. Jewett. 1981. Feeding interactions in the eastern Bering Sea with emphasis on the benthos. p. 1229-1261. *In* Hood, D.W. and J.A. Calder (eds.) *The eastern Bering Sea shelf: Oceanography and Resources*, Vol. II. Univ. Wash. Press, Seattle. 1339 p.
- Ford, J.K.B., G.M. Ellis, L.G. Barrett-Lennard, A.B. Morton, R.S. Palm, and K.C. Balcomb III. 1998. Dietary specialization in two sympatric populations of

- killer whales (*Orcinus orca*) in coastal British Columbia and adjacent waters. *Can. J. Zool.* 76: 1456-1471.
- Fritz, L. W. 1996. Squid and other species. In: Stock assessment and fishery evaluation report for the groundfish resources of the Bering Sea/Aleutian Islands regions. North Pacific Fishery Management Council, 605 W. 4th Ave., Suite 306, Anchorage, AK 99501.
- Froese, R. and D. Pauly (Ed). 1998. FishBase 98. Concepts, design and data sources. ICLARM, Manila, Philippines. 290 p.
- Frost, K.J. 1985. The ringed seal (*Phoca hispida*). Alaska Dep. Fish Game, game Tech. Bull. 7: 79-87.
- Frost, K.J. and Lowry, L.F. 1981. Foods and trophic relationships of cetaceans in the Bering Sea. p. 825-836. In D.W. Hood and J.A. Calder (eds.). The eastern Bering Sea shelf: oceanography and resources, Vol. 2, University of Washington Press, Seattle.
- Frost, K.J. and L.F. Lowry 1990. Distribution, abundance and movements of beluga whales, *Dezhnevius leucas*, in coastal waters of western Alaska. p. 39-57. In T.G. Smith, D.J. St. Aubin and J.R. Geraci (eds.), Advances in research on the beluga whale, *Dezhnevius leucas*. *Can. Bull. Fish. Aquat. Sci.* 224.
- Frost, K.J. and L.F. Lowry 1995. Distribution and abundance of beluga whales in Bristol Bay, Alaska, 1993-1994. Alaska Beluga Whale Committee Rep. 95-1. 14 pp.
- Fujioka, J.T., M.F. Sigler, and S.A. Lowe. 1996. Sablefish. In: Stock assessment and fishery evaluation report for the groundfish resources of the Bering Sea/Aleutian Islands regions. North Pacific Fishery Management Council, 605 W. 4th Ave., Suite 306, Anchorage, AK 99501.
- Fukuhara, F.M. 1985. Biology and fishery of the southeastern Bering Sea red king crab (*Paralithodes camtschatica*, Tilesius). U.S. Dep. Commer., NWAFC Processed Report 85-11. 170p.
- Gaskin, D.E. 1984. The harbour porpoise *Phocoena phocoena* (OL.): Regional populations, status, and information on direct and indirect catches. *Rep. Int. Whaling Comm.* 34: 569-586.
- Gislason, H. 1993. Effect of changes in recruitment levels on multispecies long-term predictions. *Can. J. Fish. Aquat. Sci.* 50:2315-2322.
- Gosho, M.E., D.W. Rice and J.M. Breiwick. 1984. The sperm whale, *Physeter macrocephalus*. *Mar. Fish. Rev.* 46:54-64.
- Groot, C., L. Margolis and W. C. Clarke (eds), 1995. Physiological ecology of Pacific Salmon. UBC Press, Vancouver. 510 p.

- Haflinger, K. 1981. A survey of benthic infaunal communities of the southeastern Bering Sea shelf. p. 1091-1103. In: Hood, D.W. and J.A. Calder (eds.) The eastern Bering Sea shelf: Oceanography and Resources, Vol. II. Univ. Wash. Press, Seattle. 1339p.
- Haggan, N., J. Archibald, and S. Salas 1998. Knowledge gains power when shared. Pages 8-13 in D. Pauly, T.J. Pitcher, and D. Preikshot (Eds) Back to the future: reconstructing the Strait of Georgia ecosystem. Fisheries Centre Research Reports 6(5): 99pp.
- Hall, S.J. 1999. The effects of fishing on marine ecosystems. Fish Biology and Aquatic Resources Series, Volume 1, Blackwell Science Oxford, UK, 274pp..
- Hamner, W. 1983. Gelatinous zooplankton of the Bering Sea. p. 213-229. In PROBES, Processes and Resources of the Bering Sea Shelf. Final Report - Vol. II.
- Hatch, S. A., G. V. Byrd, D.B. Irons, and G.L. Hunt Jr. 1993. Status and ecology of kittiwakes (*Rissa tridactyla* and *R. brevirostris*) in the North Pacific. p. 140-153. In K. Vermeer, K.T. Briggs, K.H. Morgan, and D. Siegel-Causey (eds.) The status, ecology, and conservation of marine birds of the North Pacific. Can. Wildl. Serv. Spec. Publ., Ottawa.
- Hill, P.S., D.P. DeMaster, and R.J. Small. 1997. Alaska marine mammal population assessments, 1996. NOAA Tech. Memo. NMFS-AFSC-78.
- Hobbs, R.C., and J.A. Lerczak. 1993. Abundance of Pacific white-sided dolphin and Dall's porpoise in Alaska estimated from sightings in the North Pacific Ocean and the Bering Sea during 1987 through 1991. Annual report to the MMPA Assessment Program, Office of Protected Resources, NMFS, NOAA, 1335 east-West
- Holling, C.S. 1973. Resilience and stability of ecological systems. Ann. Rev. Ecol. Syst. 4:1-23.
- Hollowed, A, S. R. Hare, and W.S. Wooster. 1998. Pacific basin climate variability and patterns of northeast Pacific marine fish production. In: Aha Huliko'a Workshop Proceedings
- Hunt, G.L. Jr., B. Burgeson, and G.A. Sanger. 1981. Feeding ecology of seabirds of the eastern Bering Sea. p. 629-647. In Hood, D.W. and J.A. Calder (eds.) The eastern Bering Sea shelf: Oceanography and Resources, Vol. II. Univ. Wash. Press, Seattle. 1339 p.
- Ianelli, J.N., T.K. Wilderbuer, and T.M. Sample. 1996. Stock assessment of Greenland turbot. In: Stock assessment and fishery evaluation report for the groundfish resources of the Bering Sea/Aleutian Islands regions. North Pacific Fishery Management Council, 605 W. 4th Ave., Suite 306, Anchorage, AK 99501.

- Innes, S., D.M. Lavigne, W.M. Earle and K.M. Kovacs. 1987. Feeding rates of seals and whales. *J. Anim. Ecol.* 56: 115-130.
- IPHC [International Pacific Halibut Commission]. 1996. Pacific halibut population assessment and fishery evaluation. In: Stock assessment and fishery evaluation report for the groundfish resources of the Bering Sea/Aleutian Islands regions. North Pacific Fishery Management Council, 605 W. 4th Ave., Suite 306, Anchorage, AK 99501.
- Ito, D. 1996. Other rockfish. In: Stock assessment and fishery evaluation report for the groundfish resources of the Bering Sea/Aleutian Islands regions. North Pacific Fishery Management Council, 605 W. 4th Ave., Suite 306, Anchorage, AK 99501.
- Ito, D. and J. Ianelli. 1996. Pacific ocean perch. In: Stock assessment and fishery evaluation report for the groundfish resources of the Bering Sea/Aleutian Islands regions. North Pacific Fishery Management Council, 605 W. 4th Ave., Suite 306, Anchorage, AK 99501.
- Ivashin, M.V., and L.M. Votrogov. 1981. Minke whales, *Balaenoptera acutorostrata dividsoni*, inhabiting inshore waters of the Chukotka coast. *Rep. Int. Whaling Comm.* 31: 231.
- Iverson, R.L. and J.J. Goering. 1979. Primary production and phytoplankton composition in the southeast Bering Sea. p. 144-162. In: Progress Report of Processes and Resources of the Bering Sea Shelf, Vol. 1. Univ. Alaska, Fairbanks.
- Jefferson, T.A., S. Leatherwood, and M.A. Webber. 1993. FAO species identification guide. Marine mammals of the world. United Nations Environmental Program, Food and Agriculture Organization of the United Nations, Rome.
- Johnson, M.L., C.H. Fiscus, B.T. Ostenson and M.L. Barbour. 1966. Marine mammals. p. 877-924. In N.J. Wilimovsky and J.N. Wolfe (eds), Environment of the Cape Thompson region, Alaska, U.S. Atomic Energy Comm. (available from Natl. Tech. Inf. Serv., Springfield, VA, as PNE-481).
- Kasamatsu, F. and T. Hata 1985. Notes on minke whales in the Okhotsk Sea-west Pacific area. *Rep. Int. Whaling Comm.* 35: 299-304.
- Kasuya, T. and S. Ohsumi 1984. Further analysis of the Baird's beaked whales off the Pacific coast of Japan *Sci. Rep. Whales Res. Inst.* 37: 61-83.
- Kasuya, T. and T. Miyashita. 1988. Distribution of sperm whale populations in the north Pacific. *Sci. Rep. Whales Res. Inst.* 39: 31-75.
- Kawakami, T. 1980. A review of sperm whale food. *Sci. Rep. Whales Res. Inst.* Tokyo 32: 199-218.

- Kawamura, A. 1980. A review of food of balaenopterid whales. *Sci. Rep. Whales Res. Inst. Tokyo* 32: 155-197.
- Kelly, B.P. 1988. Ringed seal, *Phoca hispida*. p. 57-75. In J.W. Lentfer (ed.), selected marine mammals of Alaska. Species accounts with research and management recommendations. Marine Mammal Commission, Washington D.C.
- Kleinenberg, S.W., A.V. Yablokov, B.M. Del'kovich, and M.N. Tarasevich. 1964. Belukha: Opyt monograficheskogo issledovaniya vida. [Beluga (*Delphinapterus leucas*): Investigation of the species.] [In Russ.] Izd. Akad. Nauk SSSR, Moscow, Natl. Tech. Inf. Serv, Springfield, VA, as TT67-51345).
- Lander R.H. 1980. Summary of northern fur seal data and collection procedures. Vol. 1: Land data of the United States and Soviet Union (excluding tag and recovery records). U.S. Dep. Commer., NOAA Tech. Memo. NMFS F/NWC-3, 315 p.
- Lander, R.H. 1981. A life table and biomass estimate for Alaskan fur seals. *Fish. Res.* 1:55-70.
- Livingston, P.A. (editor) 1991. Groundfish food habits and predation on commercially important prey species in the eastern Bering Sea from 1984 to 1986. U.S. Dep. Commer., NOAA Tech. Memo. NMFS F/NWC-207. 240p.
- Livingston, P.A. 1993. Importance of predation by groundfish, marine mammals and birds on walleye pollock *Theragra chalcogramma* and Pacific herring *Clupea pallasii* in the eastern Bering Sea. *Mar. Ecol. Prog. Ser.* 102:205-215.
- Livingston, P. A. and B. J. Goiney, Jr. 1983. Food habits literature of North Pacific marine fishes: A review and selected bibliography. U.S. Dept. Commerce, NOAA Tech. Memo. NMFS F/NWC-54.
- Livingston, P.A. and J. Jurado-Molina. In press. A multispecies virtual population analysis of the eastern Bering Sea. *ICES J. Mar. Sci.*
- Livingston, P.A. and R.D. Methot. 1998. Incorporation of predation into a population assessment model of eastern Bering Sea walleye pollock. p.x-x. In *Fishery Stock Assessment Models of the 21st Century*. Alaska Sea Grant College Program Publication. AK-SG-98-01.
- Livingston, P.A., A. Ward, G.M. Lang, and M-S. Yang. 1993. Groundfish food habits and predation on commercially important prey species in the eastern Bering Sea from 1987 to 1989. U.S. Dep. Commer., NOAA Tech. Memo. NMFS-AFSC-11. 192p.
- Lockyer, C. 1976. Body weights of some species of large whales. *J. Cons. Int. Explor. Mer* 36: 259-273.

- Lockyer, C. 1981a. Estimates of growth and energy budget for the sperm whale, *Physeter catodon*, FAO Fish. Ser. (5), Mammals in the Seas 3, 489-504.
- Lockyer, C. 1981b. Growth and energy budgets of large baleen whales from the southern hemisphere. p. 379-488. *In* FAO Advisory Committee in Marine Resources Research Working Party on Marine Mammals in the seas. Volume 3. General papers and large cetaceans.
- Loughlin, T.R. 1998. The Steller sea lion: a declining species. *Biosphere Conservation* 1: 91-98.
- Loughlin, T.R. and M.A. Perez. 1985. *Mesoplodon stejnegeri*. *Mamm. Species* 250: 1-6.
- Lowry, L.F. 1985. The spotted seal (*Phoca largha*). *Alaska Dep. Fish Game, Game Tech. Bull.* 7:89-96.
- Lowry L.F. and K.J. Frost. 1981. Feeding and trophic relationships of Phocid seals and walrus in the eastern Bering Sea. p. 813-824. *In* D.W. Hood and J.A. Calder (eds.), *The eastern Bering Sea shelf: Oceanography and resources*, Vol. 2, Univ. Washington Press, Seattle.
- Lowry, L.F. and K.J. Frost. 1984. Foods and feeding of bowhead whales in western northern Alaska. *Sci. Rep. Whales Res. Inst. Tokyo* 35: 1-16.
- Lowry, L.F., K.J. Frost, D.G. Calkins, G.L. Swartzman, and S. Hills. 1982. Feeding habits, food requirements and status of Bering Sea marine mammals. *Counc. Doc. Nos. 19 and 19A* (annotated bibliography), 574 p. North Pacific Fisheries Management Council, P.O. Box 103136, Anchorage AK 99510.
- Lowry, L.F., K.J. Frost, and T.R. Loughlin. 1989. Importance of walleye pollock in the diets of marine mammals in the Gulf of Alaska and Bering Sea and implications for fishery management. p. 701-726. *In* *Proceedings of the International Symposium on the Biology and Management of Walleye Pollock*. Alaska Sea Grant Report 89-1, Univ. Alaska, Fairbanks, AK.
- Lucas, F.A. 1899. The causes of mortality among seals. p. 75-98 *In* *The fur seals and fur seal islands of the North Pacific Ocean*. Part 3. Washington DC: U.S. Treasury Department.
- Mauchline, J. 1980. The biology of mysids and euphausiids. p. 1-681. Vol.18. *In*: Blaxter, J.H.S., F.S. Russell and M. Yonge (eds). *Adv. in Mar. Biol.* Academic Press, London.
- McDonald, J., H.M. Feder, and M. Hoberg. 1981. Bivalve molluscs of the southeastern Bering Sea. p. 1155-1204. *In*: Hood, D.W. and J.A. Calder (eds.) *The eastern Bering Sea shelf: Oceanography and Resources*, Vol. II. Univ. Wash. Press, Seattle. 1339 p.

- Merrick, R. 1995. The relationship of the foraging ecology of Steller sea lions (*Eumetopias jubatus*) to their population decline in Alaska. PhD Thesis, University of Washington.
- Merrick, R.L., M.K. Chumbley, and G.V. Byrd. 1997. Diet diversity of Steller sea lions (*Eumetopias jubatus*) and their population decline in Alaska: a potential relationship. *Canadian Journal of Fisheries and Aquatic Science* 54: 1342-1348.
- Meshcheryakova, I. M. 1964 (translated 1968). The quantitative distribution of plankton in the southeastern Bering Sea in the summers of 1958 and 1959. p. 147-158. *In* P. A. Moiseev (eds.), *Soviet fisheries investigations in the northeastern Pacific, Part II. Pishchevaya Promyshlennost, VNIRO Proc. Vol. 49 and TINRO Proc. Vol. 51, Moscow.*
- Meshcheryakova, I. M. 1970. (translated 1972). Winter and spring plankton in the southeastern part of the Bering Sea. p. 98-114 *In* P. A. Moiseev (eds.), *Soviet fisheries investigations in the northeastern Pacific. Pishchevaya Promyshlennost, VNIRO Proc. Vol. 70 and TINRO Proc. Vol. 72, Moscow.*
- Motoda, S. and T. Minoda. 1974. Plankton of the Bering Sea. p. 207-241. *In* Hood, D.W. and E.J. Kelley (eds.) *Oceanography of the Bering Sea. Inst. Mar. Sci., Occ. Pub. No. 2. Univ. Alaska, Fairbanks.*
- NRC [National Research Council]. 1996. *The Bering Sea ecosystem.* National Academy Press, Washington, D.C. 207 pp.
- Neiman, A.A. 1968. Quantitative distribution of benthos on the shelf and upper continental slope in the eastern part of the Bering Sea. p.143-217. *In*: P.A. Moiseev (editor), *Soviet Fisheries Investigations in the*
- Nemoto, T. 1957. Foods of baleen whales in the northern Pacific. *Sci. Rep. Whales Res. Inst. Tokyo* 12: 33-89.
- Nemoto, T. 1959. Food of baleen whales with reference to whale movements. *Sci. Rep. Whales Res. Inst. Tokyo* 14: 144-290.
- Nemoto, T. 1970. Feeding pattern of baleen whales in the ocean. p. 241-252. *In* J.H. Steele (ed.), *marine food chains, Oliver and Boyd, Edinburgh, UK.*
- Niebauer, H.J. 1988. Effects of El Nino-Southern Oscillation and North Pacific weather patterns on interannual variability in the subarctic Bering Sea. *J. Geophys. Res.* 93:5051-5068.
- NMFS [National Marine Fisheries Service]. 1988. *Marine Mammal Protection Act of 1972 Annual Report 1987-88.* U.S. Dep. Comm., National Oceanic and Atmospheric Admin., National Marine Fisheries Service, Office of Protected Resources, Silver Spring, MD 20910.
- NMFS [National Marine Fisheries Service]. 1991. *Recovery Plan for the Northern Right Whale (Eubalaena glacialis).* Prepared by the Right Whale Recovery

- Team for the National Marine Fisheries Service. Silver Spring, Maryland. 86 p.
- NPFMC [North Pacific Fishery Management Council]. 1996. Stock assessment and fishery evaluation report for the groundfish resources of the Bering Sea/Aleutian Islands regions. North Pacific Fishery Management Council, 605 West 4th Ave., Suite 306, Anchorage, AK 99501.
- Novikov, N.P. 1970. Biologiya maloglazogo dolgokhovosta *Chalinura pectoralis* v severnoi chasti Tikhogo okeana (Biology of *Chalinura pectoralis* in the North Pacific). Tr. Vses. Nauchno-Issled. Inst. Morsk. Rybn. Khoz. Okeanogr. 70 (Izv. Tikhookean. Nauchno-Issled. Inst. Rybn. Khoz. Okeanogr. 72):300-326. In Russ. (Transl. by Isr. Program Sci. Transl. 1972, 9. 304-331 in P.A. Moiseev (editor), Soviet Fisheries Investigations in the Northeastern Pacific, Part 5, available U.S. Dep. Commer., Natl. Tech. Inf. Serv., Springfield, Va., as TT-71-50127.)
- Odum, E.P. 1969. The strategy of ecosystem development. *Science* 104:262-270.
- Odum, E.P. 1971. Fundamentals of ecology. W.B. Saunders Co., Philadelphia. 574 p.
- Ohsumi, S. 1966. Sexual segregation of the sperm whale in the North Pacific. *Sci. Rep. Whales Res. Inst. Tokyo* 20: 1-16.
- Ohsumi, S. 1979. Interspecies relationships among some biological parameters in cetaceans and estimation of the natural mortality coefficient of the southern hemisphere minke whale. *Rep. Int. Whaling Comm. No. 29*, pp. 397-406.
- Ohsumi, S., Y. Shimadzu, and T. Doi 1971. The seventh memorandum on the results of Japanese stock assessment of whales in the North Pacific. *Rep. Int. Whaling Comm. 21: 76-89.*
- Ohsumi, S., and S. Wada. 1974. Status of whale populations in the North Pacific. 1972. *Rep. Int. Whal. Comm. 24: 114-126.*
- Okey, T. and D. Pauly (eds) 1998. Trophic mass balance model of Alaska's Prince William Sound ecosystem, for the post-spill period 1994-1996. *Fisheries Centre Research Reports* 6(4), 144pp. Okutani, T., and T. Nemoto. 1964. Squids as the food of sperm whales in the Bering Sea and Alaskan Gulf. *Sci. Rep. Whales Res. Inst. Tokyo* 18:111-122.
- Opitz, S. 1993. A quantitative model of trophic interactions in a Caribbean Coral Reef Ecosystem. p. 259-267. In V. Christensen and D. Pauly (eds.) *Trophic models of aquatic ecosystems. ICLARM Conf. Proc. 26*, 390 p.
- Otto, R.S. 1986. Management and assessment of eastern Bering Sea king crab populations, p. 83-106. In G.S. Jamieson and N. Bourne (eds.) *North*

- Pacific Workshop on Stock Assessment and Management of Invertebrates. Can. Spec. Publ. Fish. Aquat. Sci. 92.
- Otto, R.S., J.A. Haaga, and R.A. MacIntosh. 1997. Report to industry on the 1996 eastern Bering Sea crab survey. U.S. Dep. Commer., Natl. Oceanic and Atmos. Admin., Alaska Fisheries Science Center AFSC Processed Report 97-02. 52p.
- Paul, A.J. and A. Fuji. 1989. Bioenergetics of the Alaskan crab *Chionoecetes bairdi* (Decapoda: Majidae). J. Crust. Biol. 9:25-36.
- Pauly, D. (ed.) 1998. The use of Ecopath with Ecosim to evaluate strategies for sustainable exploitation of multi-species resources. Fisheries Centre Research Reports 6 (2), 49pp.
- Pauly, D. and V. Christensen. 1995. Primary production required to sustain global fisheries. Nature 374:255-257.
- Pauly, D. and V. Christensen 1996. Mass-balance models of North-eastern Pacific ecosystems. Fisheries Centre Research Reports 4(1), 131pp.
- Pauly, D., T.J. Pitcher, and D. Preikshot (eds) 1998a. Back to the future: reconstructing the Strait of Georgia ecosystem. Fisheries Centre Research Reports 6(5), 99pp.
- Pauly D., V. Christensen, J. Dalsgaard, R. Froese, F. Torres Jr. 1998b. Fishing down marine food webs. Science 279: 860-863.
- Pauly, D., A.W. Trites, E. Capuli and V. Christensen. 1998c. Diet composition and trophic levels of marine mammals. ICES Journal of Marine Science 55: 467-481.
- Pearson, W.H., D.L. Woodruff, and B.J. Higgins. 1984. Feeding ecology of juvenile king and Tanner crab in the southeastern Bering Sea. Final Report, Outer Continental Shelf Environmental Assessment Program. Battell Pacific Northwest Lab, Richland, WA 99352
- Perez, M.A. 1990. Review of marine mammal and prey population information for Bering Sea ecosystem studies. NOAA technical memorandum NMFS F/NWC-186.
- Perez, M.A. and M.A. Bigg. 1981. An assessment of the feeding habits of the northern fur seal in the eastern north Pacific Ocean and eastern Bering Sea. 140 p (unpubl. Report, available from the National Marine Mammal Laboratory, Sand Point Way, Seattle WA)
- Perez, M.A. and M.A. Bigg. 1986. Diet of northern fur seals (*Callorhinus ursinus*) off western north America. Fishery Bulletin 84:957-971.
- Pitcher, K.W. 1990. Major decline in number of harbor seals, *Phoca vitulina richardsi*) on Tugidak Island, Gulf of Alaska. Mar. Mamm. Sci. 6: 121-134.

- Pitcher, T.J. (ed.) 1996. Reinventing fisheries management. Fisheries Centre Research Reports 4(2), 84 pp. Pitcher, T.J. 1998a. Pleistocene pastures: Steller's sea cow and sea otters in the Strait of Georgia. Pages 49-52 in Pauly, D., Pitcher, T.J. and Preikshot, D. (Eds) Back to the future: reconstructing the Strait of Georgia ecosystem. Fisheries Centre Research Reports 6(5): 99pp.
- Pitcher, T.J. 1998b. Back To the future: a novel methodology and policy goal in fisheries. Pages 4-7 in D. Pauly, T.J. Pitcher, and D. Preikshot (Eds), Back to the future: reconstructing the Strait of Georgia ecosystem. Fisheries Centre Research Reports 6(5): 99pp.
- Pitcher, T.J., D. Pauly, N. Haggan, and D. Preikshot. 1999. Back to the future: a method employing ecosystem modelling to maximise the sustainable benefits from fisheries. Alaska Sea Grant Symposium 1998 (in press). Polovina, J.J. 1984. Model of a coral reef ecosystem. Part I. The Ecopath application and its application to French Frigate Shoals. Coral Reefs 3:1-11.
- Popov, L.A. 1976. Status of main ice forms of seal inhabiting waters of the U.S.S.R. and Adjacent to the country marine areas. Bergin ACMRR/MM/SC/51. 18 p.
- Queirolo, L.E., L.W. Fritz, P.A. Livingston, M.R. Loefflad, D.A. Colpo, and Y.L. deReynier. 1995. Bycatch, utilization, and discards in the commercial groundfish fisheries of the Gulf of Alaska, eastern Bering Sea, and Aleutian Islands. NOAA Tech. Memo. NMFS-AFSC-58. 148p.
- Quinn, T.J., II, and H.J. Neibauer. 1995. Relation of eastern Bering Sea walleye pollock (*Theragra chalcogramma*) recruitment to environmental and oceanographic variable, p. 497-507. In R.J. Beamish (ed.) Climate change and northern fish populations. Can. Spec. Publ. Fish. Aquat. Sci. 121.
- Radchenko, V.I. 1992. The role of squids in the pelagic ecosystem of the Bering Sea. Oceanology 32(6):762-767.
- Reilly, S.B., and J. Barlow. 1986. Rates of increase in dolphin population size. Fishery Bulletin. 84: 527-533.
- Rice, D.W. 1968. Stomach contents and feeding behaviour of killer whales in the eastern North Pacific. Nor. Hvalfangst-Tid. 57: 35-38.
- Rice, D.W. 1978. The humpback whale in the North Pacific: distribution, exploitation and numbers. Appendix 4. Pp. 29-44. In K.S. Norris and R.R. Reeves (eds.). Report on a workshop on problems related to humpback whales (*megaptera novaeangliae*) in Hawaii. U.S. Dep. Commer., Nat. Tech. Info. Serv. PB-280 794. Springfield VA.
- Rice, D.W. 1986. Beaked whales. p. 102-109. In D. Haley (ed.). Marine mammals of eastern North Pacific and arctic waters, 2nd Ed., rev., Pacific Search Press, Seattle, WA.

- Rice, D.W. and A.A. Wolman. 1971. The life history and ecology of the gray whale, *Eschrichtius robustus*. Am. Soc. Mamm. Spec. Publ. 3. 142 p.
- Rice, R.L. 1981. Feeding habits of crangonid shrimps and some aspects of sediment-detrital food systems in lower Cook Inlet, Alaska. NOAA/OMPA Principal Investigation Report on the Environmental Assessment of the Alaskan Continental Shelf, Vol. 14, Biological Studies, p.611-676.
- Ricker, W.E. 1975. Computation and interpretation of biological statistics of fish populations. Bull. Fish. Res. Board Can. 191. 382 p.
- Schneider, D. and G.L. Hunt. 1982. Carbon flux to seabirds in waters with different mixing regimes in the southeastern Bering Sea. Mar. Biol. 67:337-344.
- Seaman, G.A., K.J. Frost, and L.F. Lowry. 1985. Investigations of belukha whales in coastal waters of western and northern Alaska. Part I. Distribution, abundance and movements. U.S. Dep. Commer., NOAA, OCSEAP Final Rep. 56: 153-220.
- Sease, J.L. 1992. Status review: harbor seals (*Phoca vitulina*) in Alaska. NMFS AFSC Processed Rep. 92-15. 74 pp.
- Seitz, R.D. and L.C. Schaffner. 1995. Population ecology and secondary production of the polychaete *Loimia medusa* (Terebellidae). Mar. Biol. 121:701-711.
- Shuntov, V.P. 1972. Seasonal distribution of black and arrow-toothed halibuts in the Bering Sea. p. 397-408 In P.A. Moiseev (ed) Soviet Fisheries Investigations in the Northeastern Pacific, Part V. (Translated from Russian by Israel Program for Scientific Translations for U.S. Dept. Commerce, National Marine Fisheries Service, NTIS doc. TT 71-50127.)
- Sinclair, E., T. Loughlin, and W. Pearchy. 1994. Prey selection by northern fur seals (*Callorhinus ursinus*) in the eastern Bering Sea. Fish. Bull. 92: 144-156.
- Sissenwine, M.P., E.B. Cohen, and M.D. Grosslein. 1984. Structure of the Georges Bank ecosystem. Rapp. P.-v. Cons. int. Explor. Mer 183:243-254.
- Sleptsov, M.M. 1961. Observations of small cetaceans in far eastern seas and NW Pacific. [in Russian]. TR. Inst. Morfol. Zhivotnykh Akad. Nauk SSSR 34: 136-143. (Transl. By M. Slessers, U.S. Nav. Oceanogr. Off., Washington, D.C., 1970. NOO Transl. 482, 11p.)
- Small, R.J. and D. DeMaster. 1995. Alaska marine mammal population assessments 1995. US Dept. Commer., NOAA Tech Memo. NMFS-AFSC-57. 93 p.

- Somerton, D. 1981. Life history and population dynamics of two species of Tanner crab, *Chionoecetes bairdi* and *C. opilio*, in the eastern Bering Sea with implications for the management of the commercial harvest. Ph.D. thesis, University of Washington, Seattle, WA. 220p.
- Spencer, P.D. and J.S. Collie. 1996. A simple predator-prey model of exploited marine fish populations incorporating alternative prey. *ICES J. Mar. Sci.* 53:615-628.
- Springer, A.M., C.P. McRoy, and M.V. Flint. 1996. The Bering Sea Green Belt: shelf-edge processes and ecosystem production. *Fish. Oceanogr.* 5:205-223.
- Steele, J.H. and E.W. Henderson. 1984. Modeling long-term fluctuations in fish stocks. *Science* 224:985-987.
- Sugimoto, T. and K. Tadokoro. 1997. Interannual-interdecadal variations in zooplankton biomass, chlorophyll concentration and physical environment in the subarctic Pacific and Bering Sea. *Fish. Oceanogr.* 6:74-93.
- Tarasevich, M.N. 1968. Food connections of the sperm whales of the Northern Pacific. [in Russian]. *Zool. Zhur.* 47: 595-601. (Transl. By K. Coyle, Univ. Alaska, Fairbanks, 1982, 11 p.).
- Thompson, G.G. and M.W. Dorn. 1996. Pacific cod. In: Stock assessment and fishery evaluation report for the groundfish resources of the Bering Sea/Aleutian Islands regions. North Pacific Fishery Management Council, 605 W. 4th Ave., Suite 306, Anchorage, AK 99501.
- Thornsteinson, F.V. and C.J. Lensink. 1962. Biological observations of Steller sea lions taken during an experimental harvest. *J. Wild. Manage.* 26:353-359.
- Tomilin, A. 1957. Mammals of the USSR and Adjacent Countries, p. In V.G. Heptmer (ed.). *Cetacea: vol. IX, Nauk USSR.*
- Trites, A.W. 1989. Estimating the juvenile survival rate of male northern fur seals (*Callorhinus ursinus*). *Can. J. Fish. Aquat. Sci.* 46: 1428-1436.
- Trites, A.W. 1991. Fetal growth of northern fur seals: life history strategy and sources of variation. *Can. J. Zool.* 69: 2608-2617.
- Trites, A.W. and M.A. Bigg 1996. Physical growth of northern fur seals: seasonal fluctuations and migratory influences. *J. Zool. (Lond.)*. 238: 459-482.
- Trites, A.W. and P.A. Larkin. 1989. The decline and fall of the Pribilof fur seal (*Callorhinus ursinus*): a simulation study. *Can. J. Fish. Aquat. Sci.* 46:1437-1445.

- Trites, A.W., and P.A. Larkin. 1996. Changes in the abundance of Steller sea lions (*Eumetopias jubatus*) in Alaska from 1956 to 1992: how many were there? *Aquat Mamm.* 22:153-166.
- Trites, A.W. and P.A. Larkin. 1992. The status of Steller sea lion populations and the development of fisheries in the Gulf of Alaska and Aleutian Islands. A report of the Pacific States Marine Fisheries Commission pursuant to NOAA award no. NA17FD0177. 134 p.
- Trites, A.W., P.A. Livingston, M.C. Vasconcellos, S. Mackinson, A.M. Springer and D. Pauly. In press. Ecosystem Considerations and the Limitations of Ecosystem Models in Fisheries Management: Insights from the Bering Sea. *In* Proceedings of Ecosystem Considerations in Fisheries Management. 16th Lowell Wakefield Fisheries Symposium and American Fisheries Society joint meeting. Anchorage, Alaska, USA. September 30 – October 3, 1998.
- Trites, A.W. and D. Pauly. 1998. Estimating mean body masses of marine mammals from maximum body lengths. *Can. J. Zool.* 76: 886-896.
- Turnock, B.J., and T.J. Quinn. 1991. The effect of responsive movement on abundance estimation using line transect sampling. *Biometrics* 47: 701-715.
- Ulanowicz, R.E. 1986. Growth and development; ecosystem phenomology. Springer Verlag, New York. 203 p.
- Vasconcellos, M., S. Mackinson, K. Sloman and D. Pauly. 1997. The stability of trophic mass-balance models of marine ecosystems: a comparative analysis. *Ecological Modelling* 100:125-134.
- Venrick, E.L., J.A. McGowan, D.R. Vayan, and T.L. Hayward. 1987. Climate and chlorophyll a: Long-term trends in the central North Pacific Ocean. *Science* 238: 70-72.
- Vitousek, P.M., P.R. Ehrlich, A.H. Ehrlich and P.A. Matson. 1986. Human appropriation of the products of photosynthesis. *Bioscience* 36 368-373.
- Wada, S. 1973. The ninth memorandum on the population assessment of whales in the North Pacific. *Rep. Int. Whal. Comm.* 23: 164-169.
- Wada, S. 1980. Japanese whaling and whale sighting in the North Pacific 1978 season. *Rep. Int. Whaling Comm.* 30: 415-424.
- Wada, S. 1981. Japanese whaling and whale sighting in the North Pacific 1979 season. *Rep. Int. Whaling Comm.* 31: 783-792.
- Walsh, J.J., and C.P. McRoy. 1986. Ecosystem analysis in the southeastern Bering Sea. *Cont. Shelf Res.* 5: 259-288.

- Walters, C., V. Christensen, D. Pauly. 1997. Structuring dynamic models of exploited ecosystems from trophic mass-balance assessments. *Rev. Fish Biol. Fish.* 7, 139-172.
- Walters, G.E. and T.K. Wilderbuer. 1996. Flathead sole. In: Stock assessment and fishery evaluation report for the groundfish resources of the Bering Sea/Aleutian Islands regions. North Pacific Fishery Management Council, 605 W. 4th Ave., Suite 306, Anchorage, AK 99501.
- Walters, G.E., K. Teshima, J.J. Traynor, R.G. Bakkala, J.A. Sassano, K.L. Halliday, W.A. Karp, K. Mito, N.J. Williamson, and D. M. Smith. 1988. Distribution, abundance, and biological characteristics of groundfish in the eastern Bering Sea based on results of the U.S.-Japan triennial bottom trawl and hydroacoustic surveys during May-September 1985. U.S. Dep. Commer., NOAA Tech. Memo. NMFS F/NWC-154. 400p.
- Warwick, R.M. 1980. Population dynamics and secondary production of benthos. p. 1-24. *In* Tenore, K.R. and B.C. Coull (eds). *Marine Benthic Dynamics*. The Belle Branch Library in Marine Science Number 11. 451 p. Univ. S. Carolina Press, Columbia.
- Wespestad, V.G. 1991. Pacific herring population dynamics, early life history, and recruitment variation relative to eastern Bering Sea oceanographic factors. Ph.D. thesis, Univ. Washington, Seattle, WA, 237 p.
- Wespestad, V.G., J. Ianelli, L. Fritz, T. Honkalehto, G. Walters. 1996. Walleye pollock. In: Stock assessment and fishery evaluation report for the groundfish resources of the Bering Sea/Aleutian Islands regions. North Pacific Fishery Management Council, 605 W. 4th Ave., Suite 306, Anchorage, AK 99501.
- Wilderbuer, T.K. 1996. Yellowfin sole. In: Stock assessment and fishery evaluation report for the groundfish resources of the Bering Sea/Aleutian Islands regions. North Pacific Fishery Management Council, 605 W. 4th Ave., Suite 306, Anchorage, AK 99501.
- Wilderbuer, T.K. and G.E. Walters. 1996. Other flatfish. In: Stock assessment and fishery evaluation report for the groundfish resources of the Bering Sea/Aleutian Islands regions. North Pacific Fishery Management Council, 605 W. 4th Ave., Suite 306, Anchorage, AK 99501.
- Wilderbuer, T.K. and T.M. Sample. 1996. Arrowtooth flounder. In: Stock assessment and fishery evaluation report for the groundfish resources of the Bering Sea/Aleutian Islands regions. North Pacific Fishery Management Council, 605 W. 4th Ave., Suite 306, Anchorage, AK 99501.
- Williamson, and D.M. Smith. 1988. Distribution, abundance, and biological characteristics of groundfish in the eastern Bering Sea based on results of the U.S.-Japan triennial bottom trawl and hydroacoustic surveys during May-September 1985. U.S. Dep. Commer., NOAA Tech. Memo NMFS F/NWC-154. 400p.

- Withrow, D.E., and T.R. Loughlin 1996. Abundance and distribution of harbor seals (*Phoca vitulina richardsi*) along the north side of the Alaska Peninsula and Bristol Bay during 1995. Annual report of the MMPA Assessment Program, Office of Protected Resources, NMFS, NOAA, 1335 East-West Highway, Silver Spring, MD 20910.
- Zeh, J.E., J.C. George, and R. Suydam. 1994. Rate of increase, 1978-1993, of bowhead whales, *Balaena mysticetus*. Rep. Int. Whal. Comm. 45: 339-344.
- Zeh, J.E., A.E. Raftery and A.A. Schaffner. 1995. Revised estimates of bowhead population size and rate of increase. Unpubl. report submitted to Int. Whal. Comm. (SC/47/AS/10). 26 p.

Appendix 1 – Mass-Balance Model Details

ECOPATH - steady state mass-balance ecosystem model

Ecopath is a steady state model based on a set of simultaneous linear equations (one for each group i in the system (Christensen and Pauly 1992b). The master equation simply states that at equilibrium, for all i :

Production by (i) utilized within the system - catches of (i) - consumption of (i) by its predators = 0

This can also be put as:

$$0 = B_i \cdot (P/B)_i \cdot EE_i - F_i \cdot B_i - M_0 B_i - \sum_{j=1}^k Q_{ij} \quad (1)$$

where; B_i is the biomass of i during the period in question; P/B_i the production to biomass rate of i , equal to the total mortality rate (Z) under the assumption of equilibrium (Allen 1971); EE is the ecotrophic efficiency, i.e., the fraction of the production ($P = B_i \cdot P/B_i$) that is consumed within the system; F is the fishing mortality on i ; M_0 is the mortality rate not accounted for by consumption within the system; Q_{ij} is the amount of i consumed by j

Ecopath solves the set of simultaneous equations to produce a balanced box model ecosystem in which the energy flows are quantified.

ECOSIM - dynamic mass-balance approach for ecosystem simulation

By converting the linear equations of Ecopath models to differential equations, Ecosim provides a dynamic mass-balance approach, suitable for simulation (Walters et. al. 1997). Constructing a dynamic model from equation (1) there are three changes viz; (a) replace the left side with a rate of change of biomass; (b) for primary producers, provide a functional relationship to predict changes in (P/B_i) with biomass B_i (representing competition for light, nutrients and space); and (c) replace the static pool-pool consumption rates with functional relationships predicting how consumption will change with changes in biomass of B_i and B_j .

Generalizing for both equilibrium and non equilibrium situations, gives:

$$dB_i / dt = h(B) - M_o B_i - F B_i - \sum_{j=1}^n c_{ij}(B_i \cdot B_j) \quad (2)$$

where $h(B)$ is a function of B_i if i is a primary producer or

$h(B) = g_i \sum_{j=1}^n c_{ij}(B_i \cdot B_j)$ if i is a consumer, and $c_{ij}(B_i \cdot B_j)$ is the function used

to predict Q_{ij} from B_i and B_j (Walters et. al. 1997). For primary producers a simple saturating production relationship is used.

Using previously constructed Ecopath models, Ecosim calculates corresponding changes in biomass of each component when the fishing mortality of any particular group is altered. These dynamic simulations are plotted as coloured biomass curves. The scale differs for each curve. By altering the rate of flow between vulnerable and non-vulnerable prey different functional relationships for predators and prey can be considered. These can range from pure donor control, where the prey availability governs interactions, to top-down control where predation pressure dominates. Using equilibrium simulations, where equilibrium biomass is plotted over a range of F values, Ecosim provides the facility to predict the potential equilibrium yield for the fished group.

Appendix 2 – Species Assemblage Details

Mammals and Birds

Over 20 species of marine mammals feed on the eastern continental slope or shelf (NRC 1996). The majority of these are most abundant or occur solely during the summer months, May-October. Those most abundant in winter (November-April) include: bowhead whales, Dall's porpoise, Pacific walrus, ringed seals and bearded seals. Species that were not deemed to feed in the shelf/slope region of the eastern Bering Sea (but may feed in other areas of the north Pacific) were not included in the model. They include: Sei, Right, Cuviers and Bairds whales. The remaining 21 species of marine mammals that feed in the eastern Bering Sea were aggregated into 7 groups.

These 7 groups of marine mammals included: 1) baleen whales (fin whales, minke whales, blue whales, humpback whales, bowhead whales, and gray whales); 2) sperm whales; 3) toothed whales (beluga whales, killer whales, Dall's porpoise, and harbor porpoise); 4) beaked whales, 5) walrus and bearded seals; 6) Steller sea lions; and 7) seals (northern fur seals, harbor seals, spotted seals, ribbon seals, and ringed seals).

Sperm whales were considered a separate group from the toothed whales for two reasons. First, their high biomass and specialized diet would heavily bias the toothed whale group. Second, sperm whales were exploited at much higher rates than other toothed whales.

Pinnipeds were split into three groups. In particular, Pacific walruses and bearded seals were not included with other pinnipeds because their high biomass and peculiar diets would have heavily biased the pinniped group. Second, we were particularly interested in understanding the changes that have occurred to Steller sea lions; a species that declined dramatically over the past two decades and was recently declared an endangered species (Loughlin 1998).

Abundance. Population estimates for the 1979-1985 period came from Perez (1990), the NRC report (1996), and the 1987-1988 Marine Mammal Protection Act annual report (NMFS 1988). Estimates in the latter two documents mostly consider populations for the whole of the North Pacific. We assumed that portions of these populations are present in the Bering Sea during some part of the summer. Population estimates used in the model are contained in Table A2.1.

Growth rate. The maximum rate of population growth rate for northern fur seals and other pinnipeds is believed to be about 12% per year (Small and DeMaster 1995). The P/B ratio was therefore set at 6%, half of the maximum. Maximum rate of population increase for whales is 4% (Reilly and Barlow 1986) and the P/B ratio was estimated to be 2% (half of r_{max}).

Table A2.1. Estimated numbers of marine mammals and total biomass during summer (May-Oct) and winter (Nov-Dec) in the 1950s and 1980s. The seasonal estimates were averaged to determine annual biomass. Details are contained in the species descriptions.

	1950s				1980s			
	Numbers		Biomass (tons)		Numbers		Biomass (tons)	
	May-Oct	Nov-Apr	May-Oct	Nov-Apr	May-Oct	Nov-Apr	May-Oct	Nov-Apr
BALEEN WHALES								
Fin	10000	0	555900	0	3500	0	194565	0
Bowhead	0	100	0	3108	0	820	0	25482
Gray	2300	0	35354	0	5000	0	76858	0
Minke	3000	800	19698	5253	3000	800	19698	5253
Right	100	0	2338	0	50	0	1169	0
Blue	245	0	25170	0	160	0	16438	0
Humpback	900	0	27367	0	1407	0	42784	0
<i>Sum</i>	16545	900	665828	8360	13117	1620	351512	30735
SPERM WHALES	12850	0	425399	0	6100	0	201941	0
TOOTHED WHALES								
Beluga	8867	8867	2687	2687	8867	8867	2687	2687
Killer	290	250	636	549	290	250	636	549
Dall's porpoise	20000	10000	1226	613	20000	10000	1226	613
Harbour porpoise	15000	7500	466	233	15000	7500	466	233
<i>Sum</i>	44157	26617	5015	4081	44157	26617	5015	4081
BEAKED WHALES								
Stejnegers beaked	200	200	101	101	200	200	101	101
<i>Sum</i>	200	200	101	101	200	200	101	101
STELLER SEA LIK	73000	73000	14279	14279	48000	48000	9389	9389
WALRUS & BEARDED								
Pacific Walrus	1725	34500	1012	20234	3335	66700	1956	39120
Bearded seal	5000	150000	1000	30000	5000	150000	1000	30000
<i>Sum</i>	6725	184500	2012	50234	8335	216700	2956	69120
SEALS								
Northern fur	1561245	315081	38561	27312	690297	139284	17050	12076
Harbour seal	33000	33000	2099	2099	18000	18000	1145	1145
Spotted seal	157500	22500	7001	1000	157500	22500	7001	1000
Ringed seal	0	400000	0	17000	0	400000	0	17000
Ribbon seal	55000	55000	3930	3930	55000	55000	3930	3930
<i>Sum</i>	1806745	825581	51590	51341	920797	634784	29125	35151

Mean Weight. Estimates of mean body weight (wet, i.e., live weight) for males and females of each species were obtained from Trites and Pauly (1998). These were applied to total population estimates to derive total biomass (Table A2.1).

Ration. Unless otherwise stated, individual ration (R, in percent of body weight per day) was estimated for each sex and species using:

$$R = 0.1W^{0.8}$$

where W is the mean body weight in kg, 0.8 is from equation 23 in Innes et al. (1987), and 0.1 is a downward adjusted value (from 0.123 in Innes et al. 1987), which accounts for the difference between ingestion for growth and ingestion for maintenance.

Q/B ratios. Annual consumption to biomass ratios were calculated for each species based on their average body weight and the yearly ration. For the model input, a weighted average Q/B was calculated for each of the groups (Table A2.2). Q/B was weighted by biomass of each species to account for the large differences in the abundance of each species making up a group.

Table A2.2. The ratio of consumption (Q) to biomass (B) per year for marine mammals in the eastern Bering Sea during the 1980s.

Group	Q/B
Baleen whales	11.38
Sperm whale	4.55
Toothed whales	13.10
Beaked whales	10.51
Walrus & Bearded	11.24
Seals	15.95
Steller Sea lion	12.70

Diet. Data on diet comes primarily from the 1996 NRC report (Tables 4.9 and 4.10, p 129) and references therein (primarily Frost and Lowry 1981, and Lowry et al. 1982). Species consumed by marine mammals were matched to the 24 aggregated groups identified above (see Pauly et al. 1998c). Relative amounts consumed of each group were determined from the weighted annual consumption of the predators. For example, 6 species of baleen whales belong to the baleen whale group. As a group, they annually consume 2 million tonnes of pelagic and semi-demersal fishes, benthic invertebrates, large zooplankton and herbivorous zooplankton (Table: A2.3). We ranked the components of their diet as either major, minor or not eaten (2,1 and 0 respectively). We then weighted the importance of each component by the total amount consumed by each species of whale and by all whales combined (i.e., weighted importance equals the sum of the product of consumption and importance divided by total consumption). The proportion of the diet made up of the various prey types equaled the weighted importance divided by the sum of all weighed importances.

Table A2.3. Total consumption and the relative importance of prey types for 7 species of baleen whales. See text for details.

Baleen Whales	Consumption (t year ⁻¹)	Importance						Sum
		Pollock & pelag.	Benthic p-feed.	Epi-fauna	Cephalopods	Herb. zoop.	Large zoop.	
Fin	1420325	2	0	0	1	2	2	
Bowhead	58750	0	1	0	0	2	2	
Gray	305975	1	2	2	1	0	0	
Minke	109451	2	0	0	1	1	2	
Right	4278	0	0	0	0	2	1	
Blue	119996	1	0	1	1	2	2	
Humpback	15837	2	0	0	0	0	2	
Sum	2034612							
Weighted imp.		1.73	0.33	0.36	0.96	1.63	1.70	6.71
Proportion		0.26	0.05	0.05	0.14	0.24	0.25	1.00

1. BALEEN WHALES

Gray Whale (*Eschrichtius robustus*)

The eastern North Pacific population of Gray whales breeds along the west coast of North America and spends the summer feeding in the northern Bering, Chukchi and Beaufort Seas (Rice and Wolman 1971). Some gray whales feed in waters of southeast Alaska, British Columbia, Oregon and Washington. They are also believed to feed in the eastern Bering Sea (D. Rugh, pers. comm.). In 1987-88 the population was estimated at 20,869 (Small and DeMaster 1995) and rose to 21,597 individuals in the mid 1990s (Hill et al. 1997)

Fin Whale (*Balaenoptera physalus*)

Fin whales, once the most abundant species of whales in the world oceans (Evans 1987), and commonly taken by whalers, are presently listed as endangered (Small and DeMaster 1995). Reliable estimates of abundance are not available. Ohsumi and Wada (1974) report population ranges for the North Pacific between 13,430 and 18,630 in the early 1970s following heavy exploitation.

Over 9,000 fin whales were removed from the eastern Bering Sea from 1954 to 1971 with most of the catch occurring in the eastern Aleutians near the eastern Bering Sea shelf break. The maximum number killed in any one year was just under 1,200 whales.

Fin whale catch records look like those of other whale species (i.e., a high-sustained kills for a few short years, followed by a sharp collapse). Given that fin whales have an estimated longevity of nearly 100 years (Ohsumi 1979), the total harvest can be considered a minimum estimate of population size. Assuming that 10% of the population survived, suggests the eastern Bering Sea population consisted of 10,000 fin whales (9,000 harvested plus 1,000 surviving). Annual harvest was then calculated as 600 animals (9000 over 15 years). This is

consistent with Ohsumi et al. (1971) who report 500 to 1000 taken annually during the 1950s. Life table estimates suggest an equal sex ratio with mean weights of 59,819 kg for females and 51,361 kg for males (Trites and Pauly 1998). Note that these estimates assume that all age groups were present (calves through adults).

The 1955 estimate of 10,000 fin whales is approximately 23% of the 42,000 to 45,000 whales thought to be in the North Pacific. Applying this estimate to the 13,430 to 18,630 thought to be present in the 1970s suggest the Bering Sea population of fin whales was about 3,500 at that time. This is higher than the 1,000 fin whales estimated by Perez (1990) from relative abundance and distribution data, but is consistent with the depletion estimate of abundance (i.e., cumulative kill).

Daily ration is about 40g per kg body weight per day during summer feeding season (Lockyer 1981b). Approximate diet consists of 75% krill, 20% copepods, 5% fish (Frost and Lowry 1981).

Minke Whale (*Balaenoptera acutrostrata*)

Minke whales have a wide distribution in both hemispheres and are found in the Bering Sea mainly during spring and summer -- especially May and June -- although some may stay all year (Ivashin and Votrogov 1981). There are no population estimates for the eastern North Pacific population (Small and DeMaster 1995). Based on relative density data, Perez (1990) estimated a total summer population of 3,000 and a winter population of 800 minke whales in the eastern Bering Sea. Diet consists mainly of pelagic and semi-demersal fish (pollock, herring, capelin - 60%), and euphausiids (30%) with some copepods (9%) and cephalopods (1%) -- (Kasamatsu and Hata 1985). No catches were reported for Minke whales in the region, so we assumed the same biomass values for both periods.

Blue Whale (*Balaenoptera musculus*)

According to Jefferson et al. (1993), the Gulf of Alaska is the northern limit for Blue whales. For this reason, 10% of those found in the North Pacific were assumed to enter the southern part of the eastern Bering Sea. This gave a population of 160 for the 1980s.

Blue whales were heavily depleted by the 1950s. According to the NRC (1996) report, the initial population size of blue whales in the North Pacific was ca. 4,900 animals. Whaling started in 1889, but presumably intensified by the 1940s and 1950s with modern techniques. In the Ecopath model, we considered that the population size during the 1950s was half of the original population size, i.e., the total population size in the North Pacific was 2,450 animals. Only 10% of this value was considered to be actively feeding in the Bering Sea, given their main distribution is south of the Aleutian Islands (NRC 1996, Perez 1990). This gave a population of 245 for the 1950s. Braham (1991) reports a total of 5,761 blue whales killed between 1889 and 1965, which gives an average catch of 75 per year. The average catch for the early 1960s was used, given an annual harvest

of 200 animals in the North Pacific. This yields a catch of 20 whales per year if we assume that 10% of these were taken in the eastern Bering Sea.

Blue whales were assumed to consume 40g per kg of body weight per day during summer feeding season (Lockyer 1981b). Euphausiids are the major diet component followed by copepods and nekto-benthonic invertebrates (Table 4.10 in NRC 1996).

Humpback Whale (*Megaptera novaeanglianae*)

The size of the humpback whale population in the central North Pacific was 1,407 in 1981 (Baker and Herman 1987) and 4,005 in 1996 (Calambokidis et al. 1997). The population is believed to have increased by as much as 10% per year from the 1980s to early 1990s (Hill et al. 1997), and may have numbered 15,000 prior to exploitation (Rice 1978). Commercial whaling is believed to have removed a total 28,000 humpback whales.

Perez (1990) estimated a Bering Sea population of 150 humpback whales in the 1980s based on relative abundance and distribution data in Berzin and Rovnin (1966) and Wada (1980, 1981). We assumed the 1950s eastern Bering Sea population was 6 times larger prior to exploitation than in the 1980s, i.e., 900 whales (=6X150). This places 6% of the total North Pacific population in the eastern Bering Sea. We used the average North Pacific catch (of 1,047 whales) in the early 1950s as an index of catches in the 1950s. Again, we assumed that 6% of these were taken in the eastern Bering Sea, given an annual harvest of 63 whales.

Based on summer feeding rates, humpbacks consume approximately 4% of their body weight per day (Lockyer 1981b). Diet consists mainly of euphausiids (69%) and fish (29% - Pacific herring, juvenile salmon, capelin, smelts, walleye pollock, Arctic cod, saffron cod, Pacific sand lance, rockfishes and Atka mackerel), as well as small amounts of cephalopods (1%), copepods (1%), amphipods and other invertebrates (<1%) (Nemoto 1957, 1959, 1970; Kawamura 1980).

Bowhead Whale (*Balaena mysticetus*)

Bowheads were severely depleted during intense commercial whaling before the 20th Century (Braham 1984). The Western Arctic population was estimated at 8,200 animals in 1993 (Zeh et al. 1994, 1995). The southern end of the Bowhead whale winter distribution drops into the eastern Bering Sea, but it is a small part of their range. We therefore assumed (based on Perez 1990) that 10% of the population (820) occurred in mid-winter in the eastern Bering Sea in the 1980s. The 1996 population assessment reports the North Pacific population as currently being 7,738 animals (Hill et al. 1997).

Since Bowheads were severely depleted before the 20th century, it seems unlikely that many were present in 1955. We therefore assumed a 1955 population of 100 individuals.

Bowheads feed primarily on euphausiids (45%), amphipods (27%) and copepods (24%) and occasionally ingest other invertebrates (4%) (Tomilin 1957, Johnson et al. 1966, Lowry and Frost 1984).

Northern Right Whale (*Eubalaena glacialis*)

The pre-exploitation size of the North Pacific Stock exceeded 11,000 animals (NMFS 1991). Wada (1973) estimated a total population of 100-200 in the North Pacific. We therefore assumed a population size of 100 in 1955. Since then, Soviet vessels killed approximately 5 right whales per year. We therefore assumed a 1980s population of 50 right whales.

2. SPERM WHALES

There are at least two populations of sperm whales (*Physeter macrocephalus*) in the North Pacific - an eastern and a western Pacific population (Kasuya and Miyashita 1988). Adult males from the western Pacific migrate north of the females following mating, unlike the eastern population, which does not appear to segregate as strongly (Kasuya and Miyashita 1988). Between 40-60% of the sexually mature males from the western population are believed to migrate during the summer to high latitudes in the North Pacific, including the Bering Sea and Aleutian Islands (Ohsumi 1966). Time spent by whales on their summer feeding grounds is 2-4 months based on information in Ohsumi (1966).

Male sperm whales become sexually mature when they reach 10-20 m in length (Lockyer 1976, 1981a; Goshu et al. 1984). This corresponds to an estimated age of 11+ years. Applying weight at age curves calculated by Lockyer (1976) to the life table estimates of Trites and Pauly (1998) indicates that adult males have a mean weight of 33,105 kg.

Goshu et al. (1984) indicate the eastern Pacific population of adult males (age 11+ years) was 61,000 in 1982 and 128,500 in 1910. These animals were killed in small numbers from June to September, 1947-1954 (<200 per year) and at much higher rates from 1954-1966 (about 3,000 per year). An almost knife-edge drop in numbers killed after 1966 suggests that the western population was severely depleted by the late 1960s and no longer profitable to harvest.

Distribution maps of kills suggest that the center of distribution of the males that went north was the central Aleutian Islands. The maps further suggest that about 10% were killed on the shelf edge and in the canyons of the eastern Bering Sea. This gives an annual harvest of 300 whales during the 1950s, and an estimated eastern Bering Sea population of 6,100 adult male sperm whales in 1982 and 12,850 in 1955.

Perez (1990) estimated that the diet of sperm whales in the Bering sea consists of 82% cephalopods (mostly squid) and 18% fish, with trace ingestion of euphausiids, shrimp, crabs, other invertebrates and marine mammals. Fish eaten by sperm whales include salmon, lanternfishes, lancetfish, Pacific cod, walleye pollock, saffron cod, rockfishes, sablefish, Atka mackerel, sculpins,

lumpsuckers, lamprey, skates and rattails. These estimates were based on data in Berzin (1959), Okutani and Nemoto (1964), Tarasevich (1968) and Kawakami (1980),

3. TOOTHED WHALES

Beluga Whales (*Delphinapterus leucas*)

The two populations that occur within our study area are Bristol Bay and Norton Sound (Small and DeMaster 1995). The 1996 population assessment report claims that most belugas in the Beaufort Sea, Norton Sound and Bristol Bay, overwinter and probably feed in the eastern Bering Sea and probably feed in the area (Dave Rugh, NMML pers. comm.). The Bristol Bay population was estimated at 1,500 from the mid 1980s to mid 1990s (Seaman et al. 1985, Frost and Lowry 1990, 1995). These estimates are similar to those from the 1950s (Frost and Lowry 1990). Norton Sound was estimated to have 7,367 belugas in the early 1990s (Small and DeMaster 1995). We have no reason to believe that populations have changed much since 1955 and assumed a total population of 8,867 belugas (1,500 + 7,367) in 1955 and 1980. They are present 12 months of the year. Winter populations may be augmented by animals from the eastern Chukchi (a population of 3,710).

Belugas eat primarily pelagic and semi-demersal fishes (93%), but also cephalopods (2%), euphausiids (3%), amphipods (1%) and other invertebrates (1%) (Kleinenberg et al. 1964, Frost and Lowry 1981). In Bristol Bay, salmon and smelts are eaten. They may eat pollock in winter.

Killer Whale (*Orcinus orca*)

There are at least two forms of killer whales in the North Pacific. One called *residents* eats fish, while the other called *transients* has specialized on eating marine mammals. Barrett-Lennard et al. (1995) estimated that male and female transients in the Gulf of Alaska consume 73kg of prey per day. This value was assumed here for daily ration.

Resident killer whales in the Eastern North Pacific population range from the Chukchi and Bering Sea, along the Aleutian Islands, to the Gulf of Alaska and southward to California. Photo-identification resulted in a minimum estimate of 242 resident (fish eating) whales in the south-eastern Bering Sea, eastern Aleutian Islands and Kodiak region (Hill et al. 1997). An additional 205 have been identified in Prince William Sound, 154 in Southeast Alaska, and 163 in British Columbia (for a total of 764 resident whales). Population growth rates might be as low as 2%. We assumed that the population has not changed much since 1955 and set the resident population at 250 individuals. Their diet is fish, including Pacific cod, skates, smelt, capelin, herring, halibut, sharks, salmon and Arctic cod (Tomlin 1957, Sleptsov 1961).

Transients. Photo-identification indicates there are at least 36 transient (marine mammal eating) whales in the southeastern Bering Sea, eastern Aleutian Islands and Kodiak region (Hill et al. 1997). An additional 55 have been identified in Prince William Sound, 96 in Southeast Alaska, and 127 in British Columbia (for a

total of 314 transient whales). Population growth rates are not known but are undoubtedly low. We assumed that the population has not changed much since 1955 and set the transient population in the eastern Bering Sea at 40 individuals. Their diet consists of other marine mammals, primarily seals and sea lions but also includes minke, humpback, gray, beluga whales; harbour and Dall's porpoises (Tomlin 1957, Rice 1968, Ford et al. 1998).

The total killer whale population of resident and transient killer whales in the eastern Bering Sea is 290 in both periods. The composite diet composition was weighted according to the abundance of *residents* and *transients*.

Dall's porpoise (*Phocoenoides dalli*)

The distribution of Dall's porpoise extends to the Pribilof Islands, and may reach the Bering Strait in summer (Perez 1990). Limited surveys in Bristol Bay and the north Bering Sea resulted in an estimate of 9,000 (Hobbs and Lerczak 1993). Surveys north and south of the Aleutian chain gave an estimate of abundance of 302,000. Perez (1990) suggests the Dall population consists of 85,500 animals in the summer and 42,700 in the winter.

There is concern that boats may attract Dall's porpoise and bias the estimates by a factor of five. This means that these estimates should be multiplied by a factor of 0.2 if boats draw Dall's porpoise to them and bias the estimate (Turnock and Quinn (1991)). We therefore assumed that the population did not change between 1955 and 1980 and that it consisted of 20,000 in summer and 10,000 in winter.

Demersal fishes, octopus and squids are thought to comprise the major part of the diet. Other components include pelagic and semi-demersal fishes, euphausiids and nekto-benthonic invertebrates (NRC 1996).

Harbour porpoise (*Phocoena phocoena*)

The distribution of harbour porpoise ranges from Point Barrow, along the Alaskan coast to southern California. In 1991, the Bristol Bay population was estimated at 10,946 (Dalheim et al. 1992). The survey did not include the Bering Sea and Aleutian Islands. This is significantly higher than the 1,000 estimated by Perez (1990) and does not include the Norton Sound population. The minimum number for the Bering Sea population from the 1996 population assessment report is 8,549. Harbor porpoises that occur in the Chukchi Sea during summer probably winter in the Bering Sea (Gaskin 1984). Harbor porpoises are generally regarded as inhabitants of more inshore and shallower water compared to Dall's porpoise. We have assumed a summer population of 15,000 and a winter population of 7,500. No change in numbers was assumed to occur from 1955 to 1980.

Pelagic and semi-demersal fish form the major part of their diet. They also eat octopus, squid and nekto-benthonic invertebrates.

4. BEAKED WHALES

Stejnegers beaked whale (*Mesoplodon stejnegeri*).

This species is also known as the Bering Sea beaked whale (Loughlin and Perez 1985) and is the most frequently encountered species of *Mesoplodon* (Rice 1986). It occurs in the deep waters of the south-west Bering Sea and can probably be seen over the deep canyons that penetrate the Bering Sea shelf. There are no population estimates for this species. Limited sightings suggest a year round population of as few as 200 individuals (Perez 1990). There is no information to suggest the population was any larger or smaller 30 years earlier. The primary food is probably squid (90%), but they may also feed on fish (10%) such as salmon.

Baird's beaked whale (*Berardius bairdii*).

These whales have been sighted in the southern Bering Sea during summer (Tomilin 1957) in areas with submarine escarpments and seamounts (Kasuya and Ohsumi 1984). There is no information on abundance and harvest.

5. WALRUSES AND BEARDED SEALS

Pacific Walrus (*Odobenus rosmarus divergens*)

The population was depleted as a result of intense commercial harvesting through the 1930s and 1940s. The total population estimate (Russia and USA) was 65,500-94,400 in 1960 and 290,700-310,700 in 1980. Annual harvests were 4,500-6,500 in the 1950s, fell to 2,000-4,000 in the 1960s and 1970s, before rising again to 6,000-9,000 in the 1980s. The sex ratio of the harvest has changed from 2.5 males: 1 female in the 1960s-70s to unity in the 1980s (Fay et al. 1997).

The Bering Sea population was estimated to be 9,500 in 1960 and 66,700 in 1980 (Fay et al. 1997). Most of these animals spend the summer in the northern Bering Sea and Bering Strait and move into the eastern Bering Sea in winter. Following Perez (1990) we assumed that 5% were present in summer and 100% in winter.

Walrus prey largely upon benthic invertebrates, mostly infauna followed by epifauna and nekto benthonics. (Table 4.9 in NRC 1996).

Bearded Seal (*Erignathus barbatus*)

Bearded seals have a circumpolar range closely associated with sea ice. They tend to use shallow areas where the ice is in constant motion. Estimates of the Bering-Chukchi Sea population range from 250,000 to 300,000 (Popov 1976, Burns 1981a). Perez (1990) estimated that 50% of the population occurs in the eastern Bering Sea, predominantly during November to April. This suggests a 1980 population of about 5,000 animals in summer and 150,000 in winter. We assumed the same number in 1955. Major prey items are similar to that of the walrus but are very different from other seals. They prey largely upon benthic invertebrates. Bearded seals are an important species for Alaskan subsistence

hunters, with estimated annual harvests of 1,784 animals from 1966 to 1977 (Burns 1981a).

6. STELLER SEA LIONS

Steller sea lions (*Eumetopias jubatus*) breed on offshore rocks and islands from California to northern Japan. They generally feed within 20 km of shore during summer. The size of the population was estimated by applying life table statistics to counts of pups and adults made in the eastern Aleutian Islands (Trites and Larkin 1996). Total population (including pups) was 73,000 animals in 1955 and 48,000 in 1980. Mean weights were 186 kg for females and 210 kg for males (Trites and Pauly 1998). Sex ratios were 1.5:1.0 females to males.

Stellers were assumed to be present 12 months of the year and eat a variety of fish and cephalopods (Lowry et al. 1989, Merrick et al. 1997, Thorsteinson and Lensink 1962, Calkins and Goodwin 1988, NRC 1996). Walleye pollock are a dominant food. Small pollock (<20cm) seem to be more commonly eaten by juvenile sea lions than by older animals. According to Merrick (1995), greater than 75% of the pollock eaten are juvenile fish. Other major diet components include, Atka mackerel, squid, herring, sand lance and rockfish.

There is little information on the fluctuations of Steller sea lions that may have occurred before the 1960s. Harvest of Steller sea lions for the period were considered to be 500 individuals annually (Trites and Larkin 1992).

7. SEALS

Northern fur seal (*Callorhinus ursinus*)

Numbers of pups born on St. Paul and St. George Islands (Pribilof Islands) are tabulated in Lander (1980) and Trites (1989). St. George is home to roughly 16% of the total Pribilof population (based on pup counts made between 1966 and 1988). This means that approximately 87,800 pups were born on St. George in 1955 based on the 461,000 born on St. Paul. Similarly the 203,825 pups counted on St. Paul in 1980 suggest a St. George population of 38,825. Total size of the Pribilof population (pups and non-pups) was 2.3 million in 1955 and 1.0 million in 1980. This is based on life tables calculated by Lander (1981), Trites and Larkin (1989) and Trites and Pauly (1998) indicating that pups make up 23.8% of the population. Sex ratios at birth are 50:50 (Trites 1991). An unharvested population contains 38% males and 62% females (all ages combined). Average weight of all individuals (including pups) is 25.3 kg for females and 30.2 kg for males (Trites and Pauly 1998). During the commercial fur seal harvest, sex ratios were approximately 35:65 males to females.

Table A2.4. Numbers of northern fur seals in the eastern Bering Sea during summer and winter.

Year	Season	Males	Females	Total
1955	Summer	331,172	1,230,069	1,561,241
1955	Winter	315,018	0	315,018
1980	Summer	146,427	543,871	690,297
1980	Winter	139,284	0	139,284

Pelagic distribution data (Bigg 1990) suggests that most immature animals of ages 1 and 2 years remain outside the Bering Sea during summer, and that about 10% of the non-pups summer population remains during winter (Perez 1990). Of the winter animals, most are adult males and some are immature animals. Females and pups receive their nutrition from the Bering Sea for approximately 6 months (June through November). Other than pups, males probably do not feed very heavily during this time, having achieved most of their growth during the spring northward migration through the Gulf of Alaska (Trites and Bigg 1996).

During summer (Table A2.4), we assumed that the female population consisted of pups and animals aged 3+ years. This portion of the population makes up 82% of the female population and has a mean weight of 28.22 kg. We assumed that only male pups and an average of 25% of males between the ages of 2 and 7 years drew nutrition from the Bering Sea during summer. This consists of 41% of the male population with an average weight of 11.62 kg.

During winter (November to April), only mature males and some immature males were assumed to be present (10% age 3 years, 20% - 4, 35% - 5, 60% - 6, 80% - 7, and 100% age 8+). This represents 21% of the male population (which is 7.5% of the total population or 10% of the non-pup population) with an average weight of 86.7 kg.

Dietary information was based on that provided in the NRC report (1996, their Tables 4.9 and 4.13). These were in turn based on the following references: Frost and Lowry 1981, and Lowry et al. 1982, Lucas 1899, Perez and Bigg 1986, Sinclair et al. 1994). Dominant food items in the Bering Sea are pollock squid, capelin and pelagic nektonic invertebrates. In the eastern Bering Sea, pollock, squid and capelin counts for 70% of diet (Perez and Bigg 1981, 1986). There is a positive correlation between pollock year class strength and the amount of pollock in the diet. Pollock represent >80% of the diet of Northern fur seals, 96% of which are juveniles (Sinclair et al. 1994). Harvest of northern fur seals for the period was considered to be 22,000 individuals per year (based on numbers killed reported in Trites 1989).

Harbour Seal (*Phoca vitulina*)

Harbour seals occur in coastal waters of the north Pacific from Baja California through the Aleutian Islands to Japan. In the early 1990s, the Bering Sea population, residing primarily in Bristol Bay and the north side of the Alaska Peninsula, was estimated to be 18,322 animals (Small and DeMaster 1995).

Withrow and Loughlin (1996) estimated a 1995 population of 13,312 harbour seals in the Bering Sea.

The overall Bering sea population is thought to be declining (Small and DeMaster 1995) as it is in the Gulf of Alaska (Pitcher 1990). Data are not available on the number of animals present in 1955 or to what extent the animals were commercially hunted (estimates of annual kills range from 2,500 to 12,000 -- NRC 1996). We assumed the mid-range value (8,000) as the annual harvest for the 1950s.

An 83% decline of harbour seals has occurred at Sea Otter Island (Pribilof Islands) since 1974. Counts on the north side of the Alaska Peninsula in 1995 were less than 42% of the 1975 counts. The NRC (1996) panel felt that the 1980s population was about 55% of the 1960s; hence, we assumed there were 33,000 harbour seals in 1955 and 18,000 in 1980. Mean weights, for all ages combined, were 58.4 kg for females and 68.6 kg for males (Trites and Pauly 1998).

Little is known about the food of harbour seals in the Bering Sea (Sease 1992). Available data are summarized in Table 4.15 of the 1996 NRC report (based on Lowry et al. 1982). Major food items include herring, sand lance, smelt, sculpins, capelin, shrimp, mysids and octopus.

Largha 'Spotted' Seal (*Phoca largha*)

The primary range of the largha seal includes the Okhotsk, Bering and Chukchi Seas. Burns (1973) estimated a world population of 335,000 - 450,000, with a Bering Sea population of 200,000 - 250,000 (Lowry and Frost 1981, Lowry 1985, Burns 1986). Perez (1990) suggests that 70% of the population occurs in the eastern Bering Sea from November to April based on relative abundance data by location presented by Braham et al. 1984. He further suggests that 10% of the population remains in this region from May to October. This converts to 157,500 animals ($=0.7 \times 225,000$) during winter and 22,500 ($=0.1 \times 225,000$) in the summer, and compares to an estimate from known August haul-outs of 59,214 animals (Small and DeMaster 1995). Largha seals have never been commercially exploited. Since it is not known whether this species has experienced changes in abundance similar to the better-studied species, we assumed no change since 1955. Mean weights were 38.9 kg for females and 50.0 kg for males (Trites and Pauly 1998).

Largha seals feed primarily on fish (capelin, Pacific herring and walleye pollock -- Lowry and Frost 1981, Lowry et al. 1982, Bukhtiyarov et al. 1984). Some seals, especially young individuals also eat amphipods, shrimps, euphausiids, crabs, mysids and octopus.

Ribbon Seal (*Phoca fasciata*)

Burns (1981b) estimated the worldwide population at 240,000 in the mid-1970s, with an estimate for the Bering Sea at 90,000-100,000. The animals can be found in the Bering Sea in winter, but are much further north in the summer. Perez (1990) estimates that 60% of the population are in the eastern Bering Sea

during November -April. This suggests a population of about 55,000 in both time periods. Major diet items are fishes, both pelagic and demersal (Table 4.9 in NRC 1996).

Ringed Seal (*Phoca hispida*)

World population estimates range from 2.3 to 7.0 million, with 1.0 to 1.5 million in Alaskan waters (Kelly 1988). The winter distribution of ringed seals suggests about one-third of the population (400,000) moves into our study area during winter. This compares to the findings of Lowry et al. (1982) and Frost (1985) that at least 250,000 ringed seals occur on the shorefast ice in the Bering Sea. They are thought to have a similar diet to spotted seal; i.e., they eat semi-pelagic fish and pelagic and benthic invertebrates.

8. PISCIVOROUS BIRDS

The main species of piscivorous birds in the eastern Bering Sea are the northern fulmar, black-legged and red-legged kittiwakes, and common and thick-billed murre. Population trends at the main nesting sites of these birds on the Pribilof Islands (St. George and St. Paul) are available from counts performed during four years considered by the model between 1979 and 1985 (Climo 1993, Dragoo and Sundseth 1993). Population estimates were transformed into biomass using the mean individual weights of these species found in Hunt et al. (1981). The value for daily ration used for these species was 20% of their body weight per day (Hunt et al. 1981), which is probably conservative (Schneider and Hunt 1982). We assumed these species of birds fed in the eastern Bering Sea for approximately 300 days per year and that they consumed primarily juvenile pollock, euphausiids, and other fish (Hunt et al. 1981). Based on survival estimates of adult black-legged kittiwakes reported by Hatch et al. (1993), adult mortality rates are approximately 0.4 year⁻¹ and total population mortality rates are most likely higher.

There is no information available on the abundance of marine birds during the 1950s. According to George Hunt (pers. comm) there is no basis for claiming a major decrease in seabirds abundance before 1976. Dramatic die-offs of marine birds in the eastern Bering Sea are reported for the period between 1976 and 1984. The decline in abundance of murre in the Pribilof Islands were in the order of 25% between mid-1970s and mid-1980s (A. Springer unpubl. data). Given the above, marine birds biomass was considered the same in the 1950s and 1980s models.

Fish and Cephalopods

The eastern Bering Sea supports large populations of groundfish, including walleye pollock, Pacific cod, small and large-mouthed flounders, skates, and sculpins. Over 90% of the fish biomass estimated from bottom trawl survey of the shelf area in 1985 was composed of walleye pollock, yellowfin sole, Pacific cod, rock sole, Alaska plaice, flathead sole, sculpins, skates, and arrowtooth

flounder (Walters et al. 1988, Williamson and Smith 1988). Dominant groundfish populations in the slope regions include giant grenadier, walleye pollock, Greenland turbot, arrowtooth flounder, sablefish, Pacific ocean perch and Pacific cod. Stock assessments are regularly performed for the major groundfish species in this region to provide advice on acceptable biological catch limits to the North Pacific Fishery Management Council (NPFMC 1996). These population assessments are the primary source of catch, biomass, and mortality estimates for the 1980s model.

Food habits data on the main species of groundfish in the eastern Bering Sea have been collected by the Alaska Fisheries Science Center since about 1981 and on a regular basis since 1984. There are several reports that summarize the data used to provide diet information for groundfish for the 1980s model (see Livingston and Goiney 1983, Livingston et al. 1993, Dwyer et al. 1987, Brodeur and Livingston 1988, Livingston 1991). These data primarily reflect diet composition during the main feeding season in summer. The food habits data base at the Alaska Fisheries Science Center was used to estimate the diet of yellowfin sole, flathead sole, Pacific cod, sablefish, walleye pollock, arrowtooth flounder, Greenland turbot, rock sole, Alaska plaice, eelpouts, Pacific halibut, rockfish, Pacific herring, sculpins, and skates.

For the 1980s models, population diet composition was calculated by weighting the diet of predator size groups in geographic strata by the biomass of those size groups by area. Overall diet was then calculated using the biomass of each size group as a weighting factor. Estimates of daily rations followed the approach described in Livingston (1991), which uses information on annual growth increments and conversion efficiencies to derive annual rations for a given age group. For fish populations with a known age composition, rations were derived for each age group and an overall ration was estimated from the average age composition of the population during the 1979 to 1985 period.

For the 1950s model, two sources of information were used to calculate the biomass and harvest rates of finfish (Table A2.5). Reports of Soviet surveys in the Bering Sea were used to calculate species biomass (Vidar Westpestad, NMFS pers. comm.). Catches were obtained from Bakkala (1993).

Table A2.5. Finfish catches and biomass in the 1950s.

Species Group	Biomass		Catch	
	t km ⁻²	proportion of 1980s	t km ⁻²	proportion of 1980s
Adult pollock	4.320	0.157	0.014	0.007
Juvenile Pollock	0.942	0.157	–	–
Deepwater fish	1.011	2.484	0.0001	0.013
Large flatfish	1.169	0.615	0.002	0.019
Small flatfish	8.593	0.937	0.105	0.322
Other demersal fishes	1.146	0.294	0.001	0.007
Pelagics	–	–	0.0826	0.390

Particular aspects of each species' biology and parameter estimation details are noted below.

9,10. POLLOCK

Walleye pollock (*Theragra chalcogramma*) were broken into two groups: juvenile (ages 0 and 1) and adults (ages 2 and older) because of the cannibalism that occurs primarily on age 0 and age 1 fish. Estimates of juvenile biomass and mortality were derived from age-1 pollock biomass estimated from an integrated catch-at-age population model of pollock which included cannibalism and predation by Pacific cod and northern fur seals (Livingston and Methot 1998). Age-0 biomass was derived by back-calculating estimated age-1 numbers assuming half-yearly mortality rates for age-0 fish of 1.0, a conservative estimate compared with estimates of 2.6-3.2 obtained by Livingston (1993). Estimates of adult biomass and mortality rates were obtained from the pollock population assessment (Wespestad et al. 1996).

Biomass of adult and juvenile pollock for the 1950s (Table A2.5) was calculated as a proportion (0.157) of 1980s biomass based on surveys from 1957-60 (Vidar Wespestad pers. comm.). Adult catches were calculated as $0.014 \text{ t} \cdot \text{km}^{-2}$ based on Bakkala (1993)

11. DEEPWATER FISH

Biomass and mortality estimates for sablefish (*Anoplopoma fimbria*), rockfish (*Sebastes* spp.), and grenadier (Macrouridae) were obtained from the respective population assessment reports for each group (Fujioka et al. 1996, Ito and Ianelli 1996, Ito 1996, and Fritz 1996). Sablefish rations were estimated as described above. Rockfish and grenadier rations were assumed to equal the sablefish rations. Diet for sablefish and rockfish was estimated from the food habits data base at the Alaska Fisheries Science Center as described above. Grenadier diet was taken from Novikov (1970).

Biomass for the 1950s was calculated as $1.011 \text{ t} \cdot \text{km}^{-2}$, from Bakkala (1993) and catches were 49.66 t , i.e., $0.0001 \text{ t} \cdot \text{km}^{-2}$ (Table A2.5).

12. LARGE FLATFISH

Pacific halibut (*Hippoglossus stenolepis*) population size and mortality parameters are estimated by the International Pacific Halibut Commission (IPHC) and reported in the North Pacific Fishery Management Council's population assessment document (IPHC 1996). Greenland turbot (*Reinhardtius hippoglossoides*) and arrowtooth flounder (*Atheresthes stomias*) population biomass and mortality were obtained from Ianelli et al. (1996) and Wilderbuer and Sample (1996). Because food habits sampling for estimating Pacific halibut diet

did not begin until 1989, diet information for the 1980s model was taken from data obtained from 1989 through 1992 in the eastern Bering Sea.

Biomass of large flatfish ($1.169 \text{ t}\cdot\text{km}^{-2}$) for the 1950s was calculated as a proportion (0.615) of 1980s biomass based on surveys from 1957-60 (Vidar Wespestad). Catches (820.5 t, i.e., $0.0016 \text{ t}\cdot\text{km}^{-2}$) were taken from Bakkala (1993) (see Table A2.5).

13. SMALL FLATFISH

Small-mouthed flounders, which feed primarily on benthic infauna and epifauna, are a major presence in the inner and middle-shelf regions of the eastern Bering Sea. Biomass and mortality population parameters for yellowfin sole (*Pleuronectes asper*), rock sole (*Pleuronectes bilineatus*), Alaska plaice (*Pleuronectes quadrituberculatus*) and flathead sole (*Hippoglossoides elassodon*) were obtained from Wilderbuer (1996), Wilderbuer and Walters (1996), and Walters and Wilderbuer (1996).

Biomass of small flatfish ($8.593 \text{ t}\cdot\text{km}^{-2}$) for the 1950s was calculated as a proportion (0.937) of 1980s biomass based on surveys from 1957-60 (Vidar Wespestad, pers. comm.). Catches ($50,928 \text{ t} = 0.105 \text{ t}\cdot\text{km}^{-2}$) were taken from Bakkala (1993) (see Table A2.5).

14. PELAGICS

The Pelagics group consists primarily of Pacific herring (*Clupea pallasii*), capelin (*Mallotus villosus*), sandlance (*Ammodytes hexapterus*), lanternfish (Myctophidae) and bathylagids (Bathylagidae). Biomass estimates exist for Pacific herring (Wespestad 1991). However, the remaining species are not well-sampled in the bottom or mid-water surveys of the eastern Bering Sea due either to the mesh size of the nets used or to the lack of attention given to inshore areas. Total mortality rates were initially assumed to be those published for herring (Wespestad 1991), which range from about $0.3\text{-}1.2 \text{ year}^{-1}$ depending on age. A value of 1.0 year^{-1} was used for herring, which is commercially fished, and 0.8 year^{-1} for the other pelagics, which are not a target for fisheries. Ration and diet composition were calculated for Pacific herring as described above and was used to describe the group as a whole. Because biomass is poorly known for this group, ecotrophic efficiency was fixed at 0.9 so that biomass could be estimated by Ecopath.

Herring biomass during the late 1950s was between 600,000 and 900,000 tonnes. The high biomass values were mainly due to two large year-classes during 1957 and 1958 (Wespestad 1991). Biomass during the mid-1970s was in the order of 100,000 tonnes. There is no information available on biomass of sandlance, capelin and myctophids. Salmon biomass during the 1950s was ca. 57,000 tonnes, and 147,000 tonnes for the 1975-1980s period (NRC 1996, p.111, Fig. 4.28). Pelagics biomass was not specified in the models due to the lack of information on some pelagic species. Nevertheless, the information available

allowed us to estimate a minimum biomass value for the group in both periods: 757,000 tonnes ($1.562 \text{ t}\cdot\text{km}^{-2}$) for the 1950s, and 650,000 tonnes ($1.342 \text{ t}\cdot\text{km}^{-2}$) for the 1980s.

Catches of herring intensified in the Bering Sea during the 1960s and peaked in the early 1970s, with a brief but intense foreign fleet winter trawl fishery on the offshore winter grounds (NRC 1996). Catches were in the order of 10,000 t in 1960 (Wespestad 1991). Catches of salmon species in the eastern Bering Sea in the period of 1975 to 1980 varied between 10 and 40 million fish (NRC 1996). During the 1950s catches were between 5 and 15 million fish. To convert catches in numbers to weight we used a value of 3 kg as the mean weight of sockeye salmon (the most important species) in the North Pacific Ocean and Bering Sea (Groot et al. 1995). Catches in weight were then 75,000 t in the 1980s and 30,000 tonnes in the 1950s. The annual harvest of Pelagics in the 1950s was estimated to be 40,000 t ($0.0826 \text{ t}\cdot\text{km}^{-2}$).

15. OTHER DEMERSAL FISH

Species in this group include Pacific cod (*Gadus macrocephalus*), skates (Rajidae), sculpins (Cottidae), and eelpouts (Zoarcidae). Catch, biomass and mortality estimates for cod were obtained from Thompson and Dorn (1996). Catch and biomass of skates and sculpins are reported in Fritz (1996) and eelpout biomass was obtained from Gary Walters (personal communication, Alaska Fisheries Science Center, 7600 Sand Point Way NE, Seattle, WA 98115). Mortality estimates were initially assumed equal those of cod (0.4 year^{-1}), but were later adjusted upward to 0.6 year^{-1} for eelpouts because of the large predation on them by cod. Rations were estimated for cod and skates as described above. Rations of skates and eelpouts were assumed to be similar to skates.

Biomass in the 1950s was taken as the sum of cottidae and cod values from the Soviet surveys [cottidae = $0.790 \text{ t}\cdot\text{km}^{-2}$ (0.532 of 1980s biomass); cod = $0.356 \text{ t}\cdot\text{km}^{-2}$ (0.125 of the 1980s biomass); total $1.146 \text{ t}\cdot\text{km}^{-2}$]. Catches (505.83 t, i.e., $0.001 \text{ t}\cdot\text{km}^{-2}$) were taken from Bakkala (1993) (see Table A2.5).

16. CEPHALOPODS

Although there are several species of cephalopods in the eastern Bering Sea, we assumed the dominant species is *Berryteuthis magister*. Catch estimates of squid in the eastern Bering Sea are from Fritz (1996). Biomass, mortality and consumption rates and diet were obtained from Radchenko (1992). Because daily ration estimates for squid reported by Radchenko (1992) encompass a large range (1.1-4.2% body weight daily), gross conversion efficiency for squid was set at 0.3 so that ration could be estimated by the model. Biomass was considered the same for the 1950s model since no information could be found.

Benthics and Jellies

17. BENTHIC PARTICULATE FEEDERS

Benthic particulate feeders include snow and Tanner crabs (*Chionoecetes opilio* and *C. bairdi*), red and blue king crabs (*Paralithodes camtschatica* and *P. platypus*), and shrimp (particularly Pandalidae and Crangonidae). Biomass estimates for snow, Tanner, and king crabs were obtained from the summer bottom trawl survey of the eastern Bering Sea performed by the Alaska Fisheries Science Center (see summaries of these data in Otto et al. 1997). Shellfish catch data for the 1980s model were obtained from ADF&G (1994) and catches for the 1950s model from Otto (1986). Rations for crabs were obtained using the size-specific rations of Tanner crab in Paul and Fuji (1989) and weighting the overall ration by the size composition of each crab population. Ration for shrimp were based on estimates presented by Evans (1984) for *Crangon crangon*, a congener of the crangonid species found in the eastern Bering Sea. Diet composition for crab was obtained from Pearson et al. (1984) with increases in detrital contribution to the diet based on information presented in Brethes et al. (1994). Shrimp diet was estimated from information in Feder (1978) and Rice (1981). Mortality rates for crab were obtained from a variety of sources: Jerry Reeves (personal communication, Alaska Fisheries Science Center, 7600 Sand Point Way NE, Seattle, WA 98115), Fukuhara (1985), Somerton (1981) and Livingston et al. (1993).

Biomass of king crab during the 1950s was approximately 5 times larger than in the 1980s (NRC 1996, p. 75). This was assumed true for other species of crab and shrimps. Final biomass value in Ecopath is $29 \text{ t}\cdot\text{km}^{-2}$. Harvesting effort and catches declined in the 1950s followed by a period of low and variable catches through to 1966, before expansion to the current, full-scale fishery. Catches in 1966 were about 1 million lb. (ca. 460 t). Catches of particulate feeders for the 1950s were assumed to be $0.0098 \text{ t}\cdot\text{km}^{-2}$, based on figures from 1953-1959 reported by Otto (1986).

18. INFAUNA

Infauna consists of clams, polychaetes, and other worms (mainly Echiuridae). Surveys of infaunal biomass in the eastern Bering Sea have rarely been done. There are two primary sources of information on infaunal biomass: a survey done by Soviet scientists in 1958 (Neiman 1968) and a survey performed for the Outer Continental Shelf Environmental Assessment Program (OCSEAP) (Haflinger 1981, McDonald et al. 1981) in 1975-1977. Although the OCSEAP program samples are more recent, they encompassed a smaller portion of the eastern Bering Sea shelf than the Soviet samples. In addition, the OCSEAP samples were taken at the end of what might be considered a cold period in the eastern Bering Sea while the Soviet samples were from more of an average period (Niebauer 1988) that might be more representative of the 1980s model period. Initial biomass values for these groups for the 1980s model were taken from Neiman (1968). The diet of these infaunal groups were assumed to be 100% detritus based on the food web information presented by Feder and Jewett

(1981). P/B estimates were not available for Bering Sea infaunal groups while a wide range of estimates were available for infauna from other regions (Banse and Mosher 1980, Evans 1984, Seitz and Schaffner 1995, Sissenwine et al. 1984, Warwick 1980). The estimate of $P/B = 1.3 \text{ year}^{-1}$ for clams was obtained from Evans (1984) and initial $P/B = 3.0 \text{ year}^{-1}$ for polychaetes and worms from Seitz and Schaffner (1995) but was later changed to the 1.5 year^{-1} value reported by Sissenwine et al. (1984). Similarly, rations for these groups have not been estimated for the Bering Sea and the value used ($Q/B = 12 \text{ year}^{-1}$) was derived from Evans' (1984) estimate for clams.

19. JELLYFISH

Based on observations of taxonomic composition of trawl catches in recent years, the majority of scyphozoa in the eastern Bering Sea are believed to be *Chrysaëora melanaster*. Jellyfish biomass ($0.048 \text{ t} \cdot \text{km}^{-2}$) was derived from averaging NMFS trawl survey catches of medusae from 1982 to 1985. Jellyfish diet is assumed to consist of: 13.9% large zooplankton, 71.5% small zooplankton, 0.8% jellyfish, 1% juvenile pollock, and 12.8% crab larvae (Hamner 1983). Ration estimate of 1.09 g per gram body weight per year was derived from information in Arai (1997) on ration of *Chrysaëora* sp. in terms of nitrogen and converted to wet weight using data on water and nitrogen content of jellyfish and jellyfish prey. P/B (0.857 year^{-1}) was assumed equal to the inverse of the generation time (Allen 1971) of 14 months (Arai 1997). The biomass was assumed to be present in the 1950s. Q/B was subsequently increased to 2.0 year^{-1} while balancing the model.

20. EPIFAUNA

Species included in epifauna are hermit crabs, snails, brittlestars, and starfish. Biomass estimates for hermit crabs, snails, and starfish were obtained from the bottom trawl survey estimates of these groups for the eastern Bering Sea shelf, averaged from 1979 to 1985. Brittlestar biomass estimates were from Neiman (1968). Diet compositions were obtained from the OCSEAP studies of invertebrates summarized by Feder and Jewett (1981). P/B estimates were not available for Bering Sea species of infauna so the relationship between annual P/B and life-span derived for marine benthic invertebrates in Warwick (1980) was used, assuming most organisms in this group have life-spans of between 2 to 5 years. Ration estimates were not available for these groups, so estimates close to those of crabs were used.

No information was available on for the 1950, hence it was assumed the same as 1980s.

Plankton

21. LARGE ZOOPLANKTON

This group includes euphausiids, mysids, and amphipods. Initial biomass estimates for euphausiids of $10 \text{ t}\cdot\text{km}^{-2}$ were obtained from English (1979). A benthic amphipod biomass estimate ($2.2 \text{ t}\cdot\text{km}^{-2}$) was available from Neiman (1968) and is undoubtedly an underestimate of the total amphipod (pelagic and benthic) biomass. No initial mysid biomass estimate was available so it was initially assumed to be similar to the amphipod biomass. A P/B estimate for each of these animals based on body size considerations (Banse and Mosher 1980) would be around $2.5 - 4.0 \text{ year}^{-1}$ for an animal with a mean body weight (in energetic equivalents) of 0.02 kcal. The production and biomass estimates presented in Cooney (1981) for the Bering Sea zooplankton communities in the inner, middle, and outer shelf regions were converted into P/B ratios and combined into a total $P/B=6.46 \text{ year}^{-1}$ for the whole eastern Bering Sea shelf and slope region. Initial estimates of $P/B=2.5 \text{ year}^{-1}$ were used for each group and then later increased. Initial rations for large zooplankton were derived from estimates for Bering Sea copepods of 33.2 g per gram body weight per year (Dagg et al. 1982). These rations were later decreased to $22.0 \text{ g/g}\cdot\text{year}^{-1}$ to account for possible seasonal declines in or cessation of feeding. Diets of mysids and euphausiids were obtained from Mauchline (1980) and diet of amphipods from Barnes (1980).

Meshcheryakova (1970), estimates total zooplankton biomass (from samples taken 1961-1965) to be $42 \text{ t}\cdot\text{km}^{-2}$. In the 1980s model we have split zooplankton into large zooplankton and herbivorous zooplankton (copepods). Both groups have biomass close to those reported by Meshcheryakova (44 and $55 \text{ t}\cdot\text{km}^{-2}$, respectively). There is some uncertainty about what Meshcheryakova (1964, 1970) considered as total zooplankton biomass. If it refers to small zooplankton, then we have a good indication that zooplankton biomass probably remained the same between the 1950s and 1980s. On the other hand, data on primary and secondary production derived from baleen isotope analyses (see 23. Phytoplankton) point to higher values for the 1950s. We assumed the biomass and production of large and herbivorous zooplankton did not differ between the two modeled time periods.

22. HERBIVOROUS ZOOPLANKTON

This group consists primarily of small and large calanoid copepods of the eastern Bering Sea slope and shelf regions. Initial biomass estimates of $46.9 \text{ kg}\cdot\text{km}^{-2}$ were obtained from Motoda and Minoda (1974) and later increased to $55 \text{ kg}\cdot\text{km}^{-2}$. As with large zooplankton, estimates of P/B range from $2.50-6.46 \text{ year}^{-1}$ (Banse and Mosher 1980, Cooney 1981). A P/B estimate in the upper end of this range (6 year^{-1}) was chosen for this group to reflect its smaller size and faster turnover rate relative to large zooplankton. Rations for copepods were the same as those for large zooplankton. The diet was assumed to be composed of both phytoplankton and detritus.

23. PHYTOPLANKTON

Estimates of phytoplankton production (primary productivity) for the eastern Bering Sea range from around $160 \text{ g C m}^{-2} \text{ year}^{-1}$ for the middle and outer shelf areas to lower values of around $75 \text{ g C m}^{-2} \text{ year}^{-1}$ for the inner shelf region (Springer et al. 1996). Values range widely ($175\text{-}890 \text{ g C m}^{-2} \text{ year}^{-1}$) for the area of high production around the shelf edge region (Springer et al. 1996). Since many of the estimates are acknowledged to be minimum estimates (e.g., Walsh and McRoy 1986), we initially used values from the upper end of the range (i.e., $236.5 \text{ g C m}^{-2} \text{ year}^{-1}$ from Iverson and Goering (1979), converted to $1337 \text{ t ww km}^{-2} \text{ year}^{-1}$, assuming $0.4 \text{ g C per g dry weight}$ and $0.5 \text{ g dry wt per g wet weight}$). This value was adjusted to $1264 \text{ t ww km}^{-2} \text{ y}^{-1}$ to reflect our delineation of the eastern Bering Sea (Fig. 1).

Walsh and McRoy (1986) estimate that 17% of the annual primary production on the middle shelf is buried (i.e., lost). They estimate that as much as 49% in the outer domain is exported to the slope where it is either buried or consumed. It is not clear what proportion of this is available to consumers and what portion is buried or exported beyond our model boundaries.

Primary production that is buried or exported to other areas within the system is assumed to accumulate as detritus, and is thus not lost from the system. To account for actual transport or export of unutilized primary production (as noted by Springer et al. 1996) we specified that 10% of the primary production that ends up in detritus is lost (exported) from the system. This was implemented in the detritus fate (0.9). Changes in primary production in the Bering Sea are uncertain. Baleen isotope data has shown that there has been a significant decline in primary and secondary production (Don Schell, University of Alaska, pers. comm.). The decline has been in the order of 35 to 40% from 1950s to 1980s. We therefore used two different values for primary production: $1264 \text{ t ww km}^{-2} \text{ year}^{-1}$ for the 1980s and $1770 \text{ t ww km}^{-2} \text{ year}^{-1}$ for the 1950s. The initial estimate of turnover rate $P/B=170 \text{ year}^{-1}$ was derived from the daily turnover rates of diatoms reported in Motoda and Minoda (1974) and expanded to a half-yearly production period. However, specific values for biomass and P/B ratio for phytoplankton were adjusted during the balancing of the models (see below).

Other

24. DISCARDS AND BY-CATCH

The discard box was created to explicitly account for by-catch and discards. Catches reported from the Bering Sea already include discards and were disentangled using discard rates (the estimated percentage of total catch that was discarded) from 1990-1994 (Queirolo et al. 1995, their Table 55). Catches and discards were further explicitly assigned to different fishing gears using the proportions of the target and by-catch species catches retained and discarded by fisheries in the Bering Sea/Aleutian Islands during 1993 (Alverson and Hughes

1995). Gears were divided in the 5 types: **Bottom Trawl** (including the fisheries for pollock, Pacific cod, rock sole, Pacific Ocean perch and yellowfin sole); **Mid Water Trawl** (fishery for pollock); **Long Line** (including the fisheries for sablefish, Pacific cod and halibut); and **Pots** (including fisheries for king crab, Bairdi tanner and Opilio tanner). **Shooting and entanglement** of marine mammals were assigned as a sixth type of fishing. Table A2.6 shows the fractions of the catch weight that were landed and discarded by gear type in the eastern Bering Sea. For each gear type, the catch of non-target species (by-catch) is input to the discard box.

Discards are directly incorporated as small proportions in the diet of some groups, particularly birds and pinnipeds. Although it is impossible to determine from stomach content analysis of groundfish species whether a particular item was consumed while it was dead or alive, the following groundfish species have been observed consuming fish processing offal (fish remains thrown overboard): Pacific cod, skates, sablefish, walleye pollock, arrowtooth flounder, flathead sole, yellowfin sole and Pacific halibut (Queirolo, et al. 1995). Of these species, Pacific cod, skates, sablefish and Pacific halibut would be the species most likely to consume whole discarded fish.

Table A2.6: Catches ($t \cdot km^{-2} \cdot year^{-1}$) retained and discarded by fisheries in the Bering Sea during the 1980s (from Queirolo *et al.* 1995 and Alverson and Hughes, 1995).

Species	Bottom Trawl		Midwater Trawl		Long line		Crab pots		Pelagic		Total	
	Landed	Discard	Landed	Discard	Landed	Discard	Landed	Discard	Landed	Discard	Landed	Discard
Pollock	0.1288	0.1152	1.7658	0.0697	0.0004	0.0031	0.0000	0.0000	0.0000	0.0000	1.8950	0.1880
Cod	0.0649	0.0156	0.0016	0.0043	0.0620	0.0028	0.0000	0.0000	0.0000	0.0000	0.1285	0.0227
Halibut	0.0000	0.0015	0.0000	0.0003	0.0009	0.0003	0.0000	0.0000	0.0000	0.0000	0.0009	0.0021
Grenland turbot	0.0307	0.0179	0.0020	0.0029	0.0143	0.0092	0.0000	0.0000	0.0000	0.0000	0.0469	0.0300
Arrowtooth fl.	0.0011	0.0115	0.0001	0.0019	0.0005	0.0059	0.0000	0.0000	0.0000	0.0000	0.0017	0.0193
Flathead sole	0.0027	0.0061	0.0001	0.0010	0.0000	0.0001	0.0000	0.0000	0.0000	0.0000	0.0028	0.0072
Yellow sole	0.1882	0.0681	0.0001	0.0013	0.0001	0.0003	0.0000	0.0000	0.0000	0.0000	0.1883	0.0696
Rock sole	0.0121	0.0180	0.0000	0.0009	0.0000	0.0000	0.0000	0.0000	0.0000	0.0000	0.0121	0.0189
Alaska plaice	0.0074	0.0165	0.0002	0.0028	0.0000	0.0002	0.0000	0.0000	0.0000	0.0000	0.0076	0.0195
Herring	0.0000	0.0000	0.0000	0.0000	0.0000	0.0000	0.0000	0.0000	0.0550	0.0000	0.0550	0.0000
Other pelagics	0.0026	0.0008	0.0000	0.0000	0.0000	0.0000	0.0000	0.0000	0.1542	0.0000	0.1568	0.0008
Sablefish	0.0001	0.0000	0.0000	0.0000	0.0047	0.0001	0.0000	0.0000	0.0000	0.0000	0.0049	0.0002
Rockfish	0.0006	0.0002	0.0000	0.0000	0.0015	0.0007	0.0000	0.0000	0.0000	0.0000	0.0021	0.0009
C. bairdi	0.0000	0.0018	0.0000	0.0002	0.0000	0.0000	0.0190	0.0139	0.0000	0.0000	0.0190	0.0159
C. Opilio	0.0000	0.0044	0.0000	0.0006	0.0000	0.0000	0.0480	0.0352	0.0000	0.0000	0.0480	0.0402
King crab	0.0000	0.0034	0.0000	0.0000	0.0000	0.0000	0.0410	0.0280	0.0000	0.0000	0.0410	0.0314

25. DETRITUS

The detritus fate describes what happens to the detritus produced by each group (from unassimilated food and from decomposition of organisms). Under a steady state assumption the ecotrophic efficiency of the detritus box should equal 1.0.

Adjustments were made to the fate of detritus for each grouped based on the following assumptions:

- For marine mammals, only 25% of marine mammal detritus remains within the system. This seems to be a reasonable assumption given that most marine mammals are only present in the eastern Bering Sea during the summer;

- Birds were also set to 25% given that the corpses of most birds probably end up on land and not sea;
- All of the detritus was considered to accumulate from those found in close association with the bottom (infauna, epifauna, particulate feeders) or those restricted to the shelf area (small flatfish);
- For all other groups, we assumed that 25% of detritus was exported from the system due to transport out of the shelf/slope area of the eastern Bering Sea and into the deep ocean (leaving 75% to accumulate);
- Accumulated detritus was allowed to remain within the system (by assigning a value of 1 to the fate of detritus for the Ecopath detritus box).

Appendix 3 – Parameters for the 45-Box Ecopath Model

Table A3.1. Ecopath parameters describing the 1980s eastern Bering Sea ecosystem with 45 functional groups.

Functional Group	Biomass (t km ⁻²)	P/B (year ⁻¹)	Q/B (year ⁻¹)	Catch (t km ⁻²)
Baleen whales	0.39	0.02	11.38	0.0000
Toothed whales	0.01	0.02	13.11	0.0000
Sperm whales	0.21	0.02	4.55	0.0000
Beaked whales	0.00	0.02	10.52	0.0000
Walrus & Bearded	0.07	0.06	11.25	0.0091
Seals	0.07	0.06	15.93	0.0013
Steller sea lions	0.02	0.06	12.70	0.0001
Pisc. Birds	0.01	0.80	60.00	0.0000
Adult pollock	27.45	0.50	2.64	1.8950
Juv Pollock	6.00	2.50	8.33	0.0000
Cod	2.42	0.40	2.04	0.1285
Halibut	0.14	0.40	2.49	0.0009
Grenland turbot	0.96	0.40	2.04	0.0470
Arrowtooth flounder	0.80	0.40	2.92	0.0017
Flathead sole	0.43	0.40	2.56	0.0028
Yellow sole	6.11	0.40	2.96	0.1884
Rock sole	1.34	0.40	3.60	0.0121
Alaska plaice	1.29	0.40	2.49	0.0076
Herring	0.78	1.00	3.65	0.0550
Others pelagics	13.22	0.80	3.65	0.1568
Skates	0.29	0.40	2.56	0.0000
Sculpins	0.56	0.40	2.56	0.0000
Sablefish	0.11	0.40	2.49	0.0048
Rockfish	0.09	0.40	2.49	0.0021
Macrouridae	0.20	0.40	2.49	0.0000
Zoarcids	0.64	0.60	2.49	0.0000
Cephalopods	3.50	3.20	10.67	0.0000
C. bairdi	0.60	1.00	5.00	0.0190
C.opilio	1.60	1.00	5.00	0.0480
King crab	0.60	0.60	5.00	0.0410
Shrimp	3.00	2.04	10.20	0.0000
Clams	29.50	1.30	12.00	0.0000
Polychaetes	14.00	1.50	12.00	0.0000
Other worms	3.00	1.50	12.00	0.0000
Hermit crab	1.00	1.80	8.00	0.0000
Snail	0.52	1.80	8.00	0.0000
Brittlestar	3.00	1.50	5.00	0.0000
Starfish	1.34	1.50	5.00	0.0000
Amphipods	6.00	3.50	22.00	0.0000
Jellyfish	0.05	0.88	2.00	0.0000
Euphausiids	35.00	5.50	22.00	0.0000
Copepods	55.00	6.00	22.00	0.0000
Mysiids	3.00	3.50	22.00	0.0000
Phytoplankton	32.00	60.00	0.00	0.0000
Discards	0.00	-	-	0.0000
Detritus	0.00	-	-	0.0000

Appendix 4 – Diet Matrix Tables

Table A4.1. The estimated proportion of prey (nos. 1-24) eaten by predators (nos. 1-11) during the 1950s.

Prey	Predator											
	1	2	3	4	5	6	7	8	9	10	11	
1. Baleen whales	0.000	0.002	0.000	0.000	0.000	0.000	0.000	0.000	0.000	0.000	0.000	0.000
2. Toothed whales	0.000	0.001	0.000	0.000	0.000	0.000	0.000	0.000	0.000	0.000	0.000	0.000
3. Sperm whales	0.000	0.000	0.000	0.000	0.000	0.000	0.000	0.000	0.000	0.000	0.000	0.000
4. Beaked whales	0.000	0.000	0.000	0.000	0.000	0.000	0.000	0.000	0.000	0.000	0.000	0.000
5. Walrus&Bearded	0.000	0.001	0.000	0.000	0.000	0.000	0.000	0.000	0.000	0.000	0.000	0.000
6. Seals	0.000	0.002	0.000	0.000	0.000	0.000	0.000	0.000	0.000	0.000	0.000	0.000
7. Steller Sealion	0.000	0.001	0.000	0.000	0.000	0.000	0.000	0.000	0.000	0.000	0.000	0.000
8. Pisc. birds	0.000	0.000	0.000	0.000	0.000	0.000	0.000	0.000	0.000	0.000	0.000	0.000
9. Adult pollock2+	0.002	0.008	0.002	0.002	0.002	0.002	0.002	0.002	0.000	0.000	0.000	0.020
10. Juv. pollock0-1	0.007	0.013	0.002	0.006	0.002	0.018	0.029	0.095	0.020	0.000	0.000	0.008
11. O.Dem.Fish	0.000	0.056	0.050	0.000	0.016	0.052	0.031	0.106	0.007	0.000	0.000	0.043
12. Large Flatfish	0.000	0.053	0.000	0.000	0.013	0.046	0.003	0.000	0.001	0.000	0.000	0.000
13. Small Flatfish	0.000	0.050	0.000	0.000	0.010	0.040	0.003	0.000	0.000	0.000	0.000	0.120
14. Pelagics	0.182	0.319	0.056	0.172	0.044	0.288	0.862	0.572	0.123	0.000	0.000	0.276
15. Deepwater fish	0.000	0.053	0.050	0.333	0.013	0.046	0.000	0.000	0.000	0.000	0.000	0.000
16. Jellyfish	0.000	0.000	0.000	0.000	0.000	0.000	0.000	0.000	0.000	0.000	0.000	0.000
17. Cephalopods	0.150	0.230	0.840	0.320	0.000	0.009	0.070	0.040	0.000	0.000	0.000	0.010
18. Benth.P.Feeders	0.009	0.165	0.000	0.167	0.240	0.269	0.000	0.000	0.031	0.000	0.000	0.173
19. Infauna	0.000	0.000	0.000	0.000	0.400	0.000	0.000	0.001	0.010	0.000	0.000	0.200
20. Epifauna	0.015	0.000	0.000	0.000	0.250	0.000	0.000	0.000	0.001	0.000	0.000	0.072
21. Large Zoops	0.336	0.046	0.000	0.000	0.000	0.230	0.000	0.186	0.451	0.330	0.064	0.064
22. Herb. Zoops.	0.299	0.000	0.000	0.000	0.010	0.000	0.000	0.000	0.356	0.670	0.014	0.014
23. Phytoplankton	0.000	0.000	0.000	0.000	0.000	0.000	0.000	0.000	0.000	0.000	0.000	0.000
24. Detritus	0.000	0.000	0.000	0.000	0.000	0.000	0.000	0.000	0.000	0.000	0.000	0.000
Import	0.000	0.000	0.000	0.000	0.000	0.000	0.000	0.000	0.000	0.000	0.000	0.000
Sum	1.000	1.000	1.000	1.000	1.000	1.000	1.000	1.000	1.000	1.000	1.000	1.000

Table A4.2. The estimated proportion of prey (nos. 1-24) eaten by predators (nos. 12-22) during the 1950s.

Prey	Predator										
	12	13	14	15	16	17	18	19	20	21	22
1. Baleen whales	0.000	0.000	0.000	0.000	0.000	0.000	0.000	0.000	0.000	0.000	0.000
2. Toothed whales	0.000	0.000	0.000	0.000	0.000	0.000	0.000	0.000	0.000	0.000	0.000
3. Sperm whales	0.000	0.000	0.000	0.000	0.000	0.000	0.000	0.000	0.000	0.000	0.000
4. Beaked whales	0.000	0.000	0.000	0.000	0.000	0.000	0.000	0.000	0.000	0.000	0.000
5. Walrus&Bearded	0.000	0.000	0.000	0.000	0.000	0.000	0.000	0.000	0.000	0.000	0.000
6. Seals	0.000	0.000	0.000	0.000	0.000	0.000	0.000	0.000	0.000	0.000	0.000
7. Steller sea lion	0.000	0.000	0.000	0.000	0.000	0.000	0.000	0.000	0.000	0.000	0.000
8. Pisc. birds	0.000	0.000	0.000	0.000	0.000	0.000	0.000	0.000	0.000	0.000	0.000
9. Adult pollock 2+	0.025	0.000	0.000	0.020	0.000	0.000	0.000	0.000	0.000	0.000	0.000
10. Juv. pollock 0-1	0.084	0.003	0.000	0.014	0.002	0.000	0.000	0.000	0.000	0.000	0.000
11. O.Dem.Fish	0.009	0.003	0.000	0.003	0.000	0.000	0.000	0.000	0.000	0.000	0.000
12. Large Flatfish	0.000	0.001	0.000	0.018	0.000	0.000	0.000	0.000	0.000	0.000	0.000
13. Small Flatfish	0.010	0.010	0.000	0.100	0.000	0.000	0.000	0.000	0.000	0.000	0.000
14. Pelagics	0.703	0.021	0.000	0.356	0.008	0.210	0.000	0.000	0.000	0.000	0.000
15. Deepwater fish	0.002	0.000	0.000	0.002	0.000	0.000	0.000	0.000	0.000	0.000	0.000
16. Jellyfish	0.000	0.000	0.000	0.000	0.008	0.000	0.000	0.000	0.000	0.000	0.000
17. Cephalopods	0.004	0.000	0.000	0.110	0.000	0.190	0.000	0.000	0.000	0.000	0.000
18. Benth.P.Feeders	0.047	0.054	0.000	0.146	0.128	0.000	0.000	0.000	0.140	0.000	0.000
19. Infauna	0.002	0.600	0.005	0.102	0.000	0.000	0.300	0.000	0.300	0.000	0.000
20. Epifauna	0.009	0.084	0.000	0.020	0.000	0.000	0.037	0.000	0.008	0.000	0.000
21. Large Zoops	0.105	0.191	0.905	0.109	0.139	0.600	0.344	0.000	0.044	0.003	0.000
22. Herb. Zoops.	0.000	0.033	0.090	0.000	0.715	0.000	0.017	0.000	0.008	0.271	0.000
23. Phytoplankton	0.000	0.000	0.000	0.000	0.000	0.000	0.000	0.000	0.000	0.676	1.000
24. Detritus	0.000	0.000	0.000	0.000	0.000	0.000	0.302	1.000	0.500	0.050	0.000
Import	0.000	0.000	0.000	0.000	0.000	0.000	0.000	0.000	0.000	0.000	0.000
Sum	1.000	1.000	1.000	1.000	1.000	1.000	1.000	1.000	1.000	1.000	1.000

Table A4.3. The estimated proportion of prey (nos. 1-24) eaten by predators (nos. 1-11) during the 1980s.

Prey	Predator										
	1	2	3	4	5	6	7	8	9	10	11
1. Baleen whales	0.000	0.002	0.000	0.000	0.000	0.000	0.000	0.000	0.000	0.000	0.000
2. Toothed whales	0.000	0.001	0.000	0.000	0.000	0.000	0.000	0.000	0.000	0.000	0.000
3. Sperm whales	0.000	0.000	0.000	0.000	0.000	0.000	0.000	0.000	0.000	0.000	0.000
4. Beaked whales	0.000	0.000	0.000	0.000	0.000	0.000	0.000	0.000	0.000	0.000	0.000
5. Walrus&Bearded	0.000	0.001	0.000	0.000	0.000	0.000	0.000	0.000	0.000	0.000	0.000
6. Seals	0.000	0.002	0.000	0.000	0.000	0.000	0.000	0.000	0.000	0.000	0.000
7. Steller sea lion	0.000	0.000	0.000	0.000	0.000	0.000	0.000	0.000	0.000	0.000	0.000
8. Pisc. birds	0.000	0.000	0.000	0.000	0.000	0.000	0.000	0.000	0.000	0.000	0.000
9. Adult pollock 2+	0.064	0.081	0.012	0.041	0.020	0.037	0.063	0.000	0.000	0.000	0.229
10. Juv. pollock 0-1	0.065	0.081	0.013	0.042	0.020	0.115	0.185	0.599	0.130	0.000	0.048
11. O.Dem.Fish	0.000	0.053	0.050	0.000	0.020	0.046	0.031	0.106	0.007	0.000	0.035
12. Large Flatfish	0.000	0.053	0.000	0.000	0.020	0.046	0.003	0.000	0.001	0.000	0.000
13. Small Flatfish	0.000	0.053	0.000	0.000	0.020	0.046	0.003	0.000	0.000	0.000	0.128
14. Pelagics	0.129	0.162	0.025	0.084	0.040	0.154	0.634	0.051	0.014	0.000	0.030
15. Deepwater fish	0.000	0.053	0.050	0.333	0.020	0.046	0.000	0.000	0.000	0.000	0.000
16. Jellyfish	0.000	0.000	0.000	0.000	0.000	0.000	0.000	0.000	0.000	0.000	0.000
17. Cephalopods	0.143	0.246	0.849	0.333	0.000	0.007	0.080	0.053	0.000	0.000	0.014
18. Benth.P.Feeders	0.049	0.165	0.000	0.167	0.250	0.270	0.000	0.000	0.031	0.000	0.244
19. Infauna	0.000	0.000	0.000	0.000	0.339	0.000	0.000	0.001	0.016	0.000	0.134
20. Epifauna	0.054	0.000	0.000	0.000	0.250	0.000	0.000	0.000	0.001	0.000	0.072
21. Large Zoops	0.253	0.046	0.000	0.000	0.000	0.232	0.000	0.188	0.441	0.330	0.064
22. Herb. Zoops.	0.243	0.000	0.000	0.000	0.000	0.000	0.000	0.000	0.357	0.670	0.000
23. Phytoplankton	0.000	0.000	0.000	0.000	0.000	0.000	0.000	0.000	0.000	0.000	0.000
24. Detritus	0.000	0.001	0.001	0.000	0.001	0.001	0.001	0.002	0.002	0.000	0.002
Import	0.000	0.000	0.000	0.000	0.000	0.000	0.000	0.000	0.000	0.000	0.000
Sum	1.000	1.000	1.000	1.000	1.000	1.000	1.000	1.000	1.000	1.000	1.000

Table A4.4. The estimated proportion of prey (nos. 1-24) eaten by predators (nos. 12-22) during the 1980s.

Prey	Predator										
	12	13	14	15	16	17	18	19	20	21	22
1. Baleen whales	0.000	0.000	0.000	0.000	0.000	0.000	0.000	0.000	0.000	0.000	0.000
2. Toothed whales	0.000	0.000	0.000	0.000	0.000	0.000	0.000	0.000	0.000	0.000	0.000
3. Sperm whales	0.000	0.000	0.000	0.000	0.000	0.000	0.000	0.000	0.000	0.000	0.000
4. Beaked whales	0.000	0.000	0.000	0.000	0.000	0.000	0.000	0.000	0.000	0.000	0.000
5. Walrus&Bearded	0.000	0.000	0.000	0.000	0.000	0.000	0.000	0.000	0.000	0.000	0.000
6. Seals	0.000	0.000	0.000	0.000	0.000	0.000	0.000	0.000	0.000	0.000	0.000
7. Steller Sealion	0.000	0.000	0.000	0.000	0.000	0.000	0.000	0.000	0.000	0.000	0.000
8. Pisc. birds	0.000	0.000	0.000	0.000	0.000	0.000	0.000	0.000	0.000	0.000	0.000
9. Adult pollock2+	0.225	0.000	0.000	0.196	0.000	0.000	0.000	0.000	0.000	0.000	0.000
10. Juv. pollock0-1	0.523	0.016	0.000	0.087	0.010	0.000	0.000	0.000	0.000	0.000	0.000
11. O.Dem.Fish	0.006	0.002	0.000	0.003	0.000	0.000	0.000	0.000	0.000	0.000	0.000
12. Large Flatfish	0.000	0.001	0.000	0.018	0.000	0.000	0.000	0.000	0.000	0.000	0.000
13. Small Flatfish	0.013	0.011	0.000	0.100	0.000	0.000	0.000	0.000	0.000	0.000	0.000
14. Pelagics	0.061	0.008	0.000	0.100	0.000	0.200	0.000	0.000	0.000	0.000	0.000
15. Deepwater fish	0.002	0.000	0.000	0.002	0.000	0.000	0.000	0.000	0.000	0.000	0.000
16. Jellyfish	0.000	0.000	0.000	0.000	0.008	0.000	0.000	0.000	0.000	0.000	0.000
17. Cephalopods	0.004	0.000	0.000	0.123	0.000	0.200	0.000	0.000	0.000	0.000	0.000
18. Benth.P.Feeders	0.048	0.055	0.000	0.236	0.128	0.000	0.000	0.000	0.004	0.000	0.000
19. Infauna	0.002	0.623	0.005	0.002	0.000	0.000	0.317	0.000	0.308	0.000	0.000
20. Epifauna	0.009	0.084	0.000	0.020	0.000	0.000	0.037	0.000	0.008	0.000	0.000
21. Large Zoops	0.105	0.198	0.905	0.111	0.139	0.600	0.338	0.000	0.044	0.003	0.000
22. Herb. Zoops.	0.000	0.000	0.090	0.000	0.715	0.000	0.000	0.000	0.000	0.213	0.000
23. Phytoplankton	0.000	0.000	0.000	0.000	0.000	0.000	0.000	0.000	0.000	0.676	1.000
24. Detritus	0.002	0.002	0.000	0.002	0.000	0.000	0.308	1.000	0.636	0.108	0.000
Import	0.000	0.000	0.000	0.000	0.000	0.000	0.000	0.000	0.000	0.000	0.000
Sum	1.000	1.000	1.000	1.000	1.000	1.000	1.000	1.000	1.000	1.000	1.000

Appendix 5 – Niche Overlap Tables

Table A5.1. Estimated predator niche overlaps for all 24 groups of species in the 1950s. See section Niche Overlaps for explanations. Overlaps > 0.40 are in bold characters.

Predator Overlap 1950s												
Group Name	1	2	3	4	5	6	7	8	9	10	11	12
1. Baleen whales	1.00	-	-	-	-	-	-	-	-	-	-	-
2. Toothed whales	1.00	1.00	-	-	-	-	-	-	-	-	-	-
3. Sperm whales	-	-	-	-	-	-	-	-	-	-	-	-
4. Beaked whales	-	-	-	-	-	-	-	-	-	-	-	-
5. Walrus&Bearded	1.00	1.00	-	-	1.00	-	-	-	-	-	-	-
6. Seals	1.00	1.00	-	-	1.00	1.00	-	-	-	-	-	-
7. Steller sea lion	1.00	1.00	-	-	1.00	1.00	1.00	-	-	-	-	-
8. Pisc. birds	-	-	-	-	-	-	-	-	-	-	-	-
9. Adult pollock 2+	0.00	0.00	-	-	0.00	0.00	0.00	-	1.00	-	-	-
10. Juv. pollock 0-1	0.00	0.00	-	-	0.00	0.00	0.00	-	0.43	1.00	-	-
11. O.Dem.Fish	0.01	0.01	-	-	0.01	0.01	0.01	-	0.95	0.45	1.00	-
12. Large Flatfish	0.06	0.06	-	-	0.06	0.06	0.06	-	0.06	0.25	0.12	1.00
13. Small Flatfish	0.00	0.00	-	-	0.00	0.00	0.00	-	0.98	0.35	0.96	0.09
14. Pelagics	0.00	0.00	-	-	0.00	0.00	0.00	-	0.53	0.48	0.54	0.12
15. Deepwater fish	0.04	0.04	-	-	0.04	0.04	0.04	-	0.03	0.07	0.15	0.51
16. Jellyfish	-	-	-	-	-	-	-	-	-	-	-	-
17. Cephalopods	0.00	0.00	-	-	0.00	0.00	0.00	-	0.04	0.04	0.05	0.02
18. Benth.P.Feeders	0.00	0.00	-	-	0.00	0.00	0.00	-	0.45	0.26	0.47	0.13
19. Infauna	-	-	-	-	-	-	-	-	0.06	0.06	0.07	0.06
20. Epifauna	-	-	-	-	-	-	-	-	0.16	0.10	0.18	0.07
21. Large Zoops	-	-	-	-	-	-	-	-	0.01	0.05	0.02	0.02
22. Herb. Zoops.	-	-	-	-	-	-	-	-	0.00	0.01	0.00	0.00
23. Phytoplankton	-	-	-	-	-	-	-	-	-	-	-	-

Predator Overlap 1950s continued											
Group Name	13	14	15	16	17	18	19	20	21	22	23
1. Baleen whales	-	-	-	-	-	-	-	-	-	-	-
2. Toothed whales	-	-	-	-	-	-	-	-	-	-	-
3. Sperm whales	-	-	-	-	-	-	-	-	-	-	-
4. Beaked whales	-	-	-	-	-	-	-	-	-	-	-
5. Walrus&Bearded	-	-	-	-	-	-	-	-	-	-	-
6. Seals	-	-	-	-	-	-	-	-	-	-	-
7. Steller sea lion	-	-	-	-	-	-	-	-	-	-	-
8. Pisc. birds	-	-	-	-	-	-	-	-	-	-	-
9. Adult pollock 2+	-	-	-	-	-	-	-	-	-	-	-
10. Juv. pollock 0-1	-	-	-	-	-	-	-	-	-	-	-
11. O.Dem.Fish	-	-	-	-	-	-	-	-	-	-	-
12. Large Flatfish	-	-	-	-	-	-	-	-	-	-	-
13. Small Flatfish	1.00	-	-	-	-	-	-	-	-	-	-
14. Pelagics	0.48	1.00	-	-	-	-	-	-	-	-	-
15. Deepwater fish	0.02	0.05	1.00	-	-	-	-	-	-	-	-
16. Jellyfish	-	-	-	1.00	-	-	-	-	-	-	-
17. Cephalopods	0.03	0.74	0.18	-	1.00	-	-	-	-	-	-
18. Benth.P.Feeders	0.46	0.28	0.04	0.00	0.02	1.00	-	-	-	-	-
19. Infauna	0.08	0.04	-	-	0.00	0.23	1.00	-	-	-	-
20. Epifauna	0.19	0.10	0.00	-	0.01	0.16	0.98	1.00	-	-	-
21. Large Zoops	0.01	0.16	0.00	-	0.17	0.03	0.60	0.59	1.00	-	-
22. Herb. Zoops.	0.00	0.00	-	-	0.00	0.00	0.01	0.01	0.06	1.00	-
23. Phytoplankton	-	-	-	-	-	-	-	-	-	-	-

Table A5.2. Estimated predator niche overlaps for all 24 groups of species in the 1950s. See section Niche Overlaps for explanations. Overlaps > 0.40 are in bold characters.

Predator Overlap 1980s												
Group Name	1	2	3	4	5	6	7	8	9	10	11	12
1. Baleen whales	1.00	-	-	-	-	-	-	-	-	-	-	-
2. Toothed whales	1.00	1.00	-	-	-	-	-	-	-	-	-	-
3. Sperm whales	-	-	-	-	-	-	-	-	-	-	-	-
4. Beaked whales	-	-	-	-	-	-	-	-	-	-	-	-
5. Walrus&Bearded	1.00	1.00	-	-	1.00	-	-	-	-	-	-	-
6. Seals	1.00	1.00	-	-	1.00	1.00	-	-	-	-	-	-
7. Steller sea lion	-	-	-	-	-	-	-	-	-	-	-	-
8. Pisc. birds	-	-	-	-	-	-	-	-	-	-	-	-
9. Adult pollock 2+	0.00	0.00	-	-	0.00	0.00	-	-	1.00	-	-	-
10. Juv. pollock0-1	-	-	-	-	-	-	-	-	0.16	1.00	-	-
11. O.Dem.Fish	0.01	0.01	-	-	0.01	0.01	-	-	0.46	0.83	1.00	-
12. Large Flatfish	0.05	0.05	-	-	0.05	0.05	-	-	0.03	0.71	0.71	1.00
13. Small Flatfish	0.01	0.01	-	-	0.01	0.01	-	-	0.87	0.07	0.50	0.11
14. Pelagics	0.00	0.00	-	-	0.00	0.00	-	-	0.06	0.14	0.13	0.12
15. Deepwater fish	0.07	0.07	-	-	0.07	0.07	-	-	0.08	0.04	0.12	0.40
16. Jellyfish	-	-	-	-	-	-	-	-	-	-	-	-
17. Cephalopods	0.00	0.00	-	-	0.00	0.00	-	-	0.03	0.00	0.02	0.00
18. Benth.P.Feeders	0.00	0.00	-	-	0.00	0.00	-	-	0.56	0.64	0.90	0.68
19. Infauna	-	-	-	-	-	-	-	-	0.04	0.08	0.13	0.24
20. Epifauna	-	-	-	-	-	-	-	-	0.20	0.07	0.20	0.26
21. Large Zoops	-	-	-	-	-	-	-	-	0.01	0.43	0.42	0.40
22. Herb. Zoops.	-	-	-	-	-	-	-	-	-	0.12	0.10	0.09
23. Phytoplankton	-	-	-	-	-	-	-	-	-	-	-	-

Predator Overlap 1980s <i>continued</i>												
Group Name	13	14	15	16	17	18	19	20	21	22	23	
1. Baleen whales	-	-	-	-	-	-	-	-	-	-	-	
2. Toothed whales	-	-	-	-	-	-	-	-	-	-	-	
3. Sperm whales	-	-	-	-	-	-	-	-	-	-	-	
4. Beaked whales	-	-	-	-	-	-	-	-	-	-	-	
5. Walrus&Bearded	-	-	-	-	-	-	-	-	-	-	-	
6. Seals	-	-	-	-	-	-	-	-	-	-	-	
7. Steller Sealion	-	-	-	-	-	-	-	-	-	-	-	
8. Pisc. birds	-	-	-	-	-	-	-	-	-	-	-	
9. Adult pollock2+	-	-	-	-	-	-	-	-	-	-	-	
10. Juv. pollock0-1	-	-	-	-	-	-	-	-	-	-	-	
11. O.Dem.Fish	-	-	-	-	-	-	-	-	-	-	-	
12. Large Flatfish	-	-	-	-	-	-	-	-	-	-	-	
13. Small Flatfish	1.00	-	-	-	-	-	-	-	-	-	-	
14. Pelagics	0.04	1.00	-	-	-	-	-	-	-	-	-	
15. Deepwater fish	0.04	0.02	1.00	-	-	-	-	-	-	-	-	
16. Jellyfish	-	-	-	1.00	-	-	-	-	-	-	-	
17. Cephalopods	0.02	0.98	0.07	-	1.00	-	-	-	-	-	-	
18. Benth.P.Feeders	0.66	0.12	0.08	0.00	0.01	1.00	-	-	-	-	-	
19. Infauna	0.22	0.03	0.00	-	-	0.37	1.00	-	-	-	-	
20. Epifauna	0.40	0.04	0.02	-	0.01	0.50	0.92	1.00	-	-	-	
21. Large Zoops	0.03	0.37	0.00	-	0.29	0.36	0.23	0.21	1.00	-	-	
22. Herb. Zoops.	-	0.02	-	-	-	0.07	0.01	0.00	0.14	1.00	-	
23. Phytoplankton	-	-	-	-	-	-	-	-	-	-	-	

Table A5.3. Estimated prey niche overlaps for all 24 groups of species in the 1950s. See section Niche Overlaps for explanations. Overlaps > 0.40 are in bold characters.

Prey Overlap 1950s												
Group Name	1	2	3	4	5	6	7	8	9	10	11	12
1. Baleen whales	1.00	-	-	-	-	-	-	-	-	-	-	-
2. Toothed whales	0.48	1.00	-	-	-	-	-	-	-	-	-	-
3. Sperm whales	0.28	0.48	1.00	-	-	-	-	-	-	-	-	-
4. Beaked whales	0.31	0.75	0.60	1.00	-	-	-	-	-	-	-	-
5. Walrus&Bearded	0.06	0.24	0.01	0.19	1.00	-	-	-	-	-	-	-
6. Seals	0.56	0.77	0.06	0.46	0.32	1.00	-	-	-	-	-	-
7. Steller sea lion	0.33	0.62	0.15	0.33	0.07	0.52	1.00	-	-	-	-	-
8. Pisc. birds	0.54	0.72	0.13	0.34	0.08	0.72	0.89	1.00	-	-	-	-
9. Adult pollock 2+	0.93	0.24	0.01	0.09	0.07	0.53	0.19	0.43	1.00	-	-	-
10. Juv. pollock 0-1	0.76	0.04	-	-	0.02	0.20	-	0.13	0.86	1.00	-	-
11. O.Dem.Fish	0.37	0.71	0.06	0.36	0.68	0.76	0.52	0.63	0.29	0.08	1.00	-
12. Large Flatfish	0.43	0.68	0.07	0.33	0.11	0.66	0.96	0.96	0.32	0.06	0.62	1.00
13. Small Flatfish	0.24	0.08	0.00	0.04	0.80	0.21	0.03	0.12	0.29	0.18	0.53	0.09
14. Pelagics	0.61	0.08	-	-	0.01	0.40	-	0.28	0.75	0.52	0.12	0.14
15. Deepwater fish	0.53	0.90	0.25	0.52	0.41	0.84	0.67	0.80	0.37	0.10	0.91	0.77
16. Jellyfish	0.65	0.08	-	0.06	0.09	0.18	0.01	0.07	0.72	0.95	0.12	0.05
17. Cephalopods	0.77	0.44	0.30	0.27	0.03	0.61	0.33	0.58	0.75	0.40	0.32	0.44
18. Benth.P.Feeders	0.43	0.06	-	-	0.44	0.31	-	0.19	0.51	0.29	0.36	0.09
19. Infauna	-	-	-	-	-	-	-	-	-	-	-	-
20. Epifauna	0.06	0.09	-	0.07	0.48	0.17	-	0.02	0.08	0.04	0.33	0.03
21. Large Zoops	0.21	-	-	-	0.01	0.00	-	0.00	0.22	0.33	0.01	-
22. Herb. Zoops.	-	-	-	-	-	-	-	-	-	-	-	-
23. Phytoplankton	-	-	-	-	-	-	-	-	-	-	-	-

Prey Overlap 1950 continued												
Group Name	13	14	15	16	17	18	19	20	21	22	23	
1. Baleen whales	-	-	-	-	-	-	-	-	-	-	-	-
2. Toothed whales	-	-	-	-	-	-	-	-	-	-	-	-
3. Sperm whales	-	-	-	-	-	-	-	-	-	-	-	-
4. Beaked whales	-	-	-	-	-	-	-	-	-	-	-	-
5. Walrus&Bearded	-	-	-	-	-	-	-	-	-	-	-	-
6. Seals	-	-	-	-	-	-	-	-	-	-	-	-
7. Steller sea lion	-	-	-	-	-	-	-	-	-	-	-	-
8. Pisc. birds	-	-	-	-	-	-	-	-	-	-	-	-
9. Adult pollock 2+	-	-	-	-	-	-	-	-	-	-	-	-
10. Juv. pollock 0-1	-	-	-	-	-	-	-	-	-	-	-	-
11. O.Dem.Fish	-	-	-	-	-	-	-	-	-	-	-	-
12. Large Flatfish	-	-	-	-	-	-	-	-	-	-	-	-
13. Small Flatfish	1.00	-	-	-	-	-	-	-	-	-	-	-
14. Pelagics	0.29	1.00	-	-	-	-	-	-	-	-	-	-
15. Deepwater fish	0.33	0.19	1.00	-	-	-	-	-	-	-	-	-
16. Jellyfish	0.12	0.28	0.10	1.00	-	-	-	-	-	-	-	-
17. Cephalopods	0.28	0.86	0.51	0.17	1.00	-	-	-	-	-	-	-
18. Benth.P.Feeders	0.70	0.56	0.28	0.14	0.56	1.00	-	-	-	-	-	-
19. Infauna	-	-	-	-	-	0.46	1.00	-	-	-	-	-
20. Epifauna	0.51	0.07	0.20	0.07	0.07	0.77	0.73	1.00	-	-	-	-
21. Large Zoops	0.02	0.04	-	0.36	0.00	0.05	0.07	0.06	1.00	-	-	-
22. Herb. Zoops.	-	-	-	-	-	-	-	-	0.88	1.00	-	-
23. Phytoplankton	-	-	-	-	-	-	-	-	-	-	-	-

Table A5.4. Estimated prey niche overlaps for all 24 groups of species in the 1950s. See section Niche Overlaps for explanations. Overlaps > 0.40 are in bold characters.

Prey Overlap 1980s												
Group Name	1	2	3	4	5	6	7	8	9	10	11	12
1. Baleen whales	1.00	-	-	-	-	-	-	-	-	-	-	-
2. Toothed whales	0.55	1.00	-	-	-	-	-	-	-	-	-	-
3. Sperm whales	0.28	0.51	1.00	-	-	-	-	-	-	-	-	-
4. Beaked whales	0.33	0.74	0.61	1.00	-	-	-	-	-	-	-	-
5. Walrus&Bearded	0.16	0.29	0.01	0.21	1.00	-	-	-	-	-	-	-
6. Seals	0.59	0.66	0.04	0.38	0.39	1.00	-	-	-	-	-	-
7. Steller sea lion	0.35	0.49	0.15	0.26	0.09	0.40	1.00	-	-	-	-	-
8. Pisc. birds	0.34	0.31	0.10	0.14	0.05	0.43	0.35	1.00	-	-	-	-
9. Adult pollock 2+	0.82	0.16	0.00	0.04	0.06	0.50	0.08	0.43	1.00	-	-	-
10. Juv. pollock0-1	0.67	0.04	-	-	-	0.21	-	0.13	0.86	1.00	-	-
11. O.Dem.Fish	0.33	0.55	0.04	0.28	0.67	0.64	0.15	0.16	0.18	0.06	1.00	-
12. Large Flatfish	0.33	0.35	0.03	0.15	0.11	0.45	0.38	0.90	0.34	0.08	0.40	1.00
13. Small Flatfish	0.19	0.07	-	0.03	0.72	0.21	0.02	0.11	0.26	0.13	0.39	0.09
14. Pelagics	0.50	0.09	-	-	0.00	0.42	-	0.27	0.74	0.52	0.12	0.16
15. Deepwater fish	0.55	0.83	0.25	0.49	0.39	0.80	0.34	0.30	0.28	0.10	0.86	0.49
16. Jellyfish	0.60	0.08	-	0.05	0.08	0.19	0.00	0.07	0.73	0.95	0.11	0.06
17. Cephalopods	0.67	0.38	0.30	0.24	0.02	0.56	0.32	0.31	0.69	0.40	0.16	0.19
18. Benth.P.Feeders	0.36	0.07	-	-	0.42	0.32	-	0.18	0.48	0.26	0.29	0.11
19. Infauna	-	0.00	0.00	-	0.00	0.00	0.00	0.00	0.00	-	0.00	0.00
20. Epifauna	0.03	0.01	0.00	0.00	0.29	0.04	0.00	0.02	0.06	0.03	0.14	0.02
21. Large Zoops	0.15	-	-	-	-	0.00	-	0.00	0.18	0.27	0.00	0.00
22. Herb. Zoops.	-	-	-	-	-	-	-	-	-	-	-	-
23. Phytoplankton	-	-	-	-	-	-	-	-	-	-	-	-

Prey Overlap 1980s continued												
Group Name	13	14	15	16	17	18	19	20	21	22	23	
1. Baleen whales	-	-	-	-	-	-	-	-	-	-	-	
2. Toothed whales	-	-	-	-	-	-	-	-	-	-	-	
3. Sperm whales	-	-	-	-	-	-	-	-	-	-	-	
4. Beaked whales	-	-	-	-	-	-	-	-	-	-	-	
5. Walrus&Bearded	-	-	-	-	-	-	-	-	-	-	-	
6. Seals	-	-	-	-	-	-	-	-	-	-	-	
7. Steller sea lion	-	-	-	-	-	-	-	-	-	-	-	
8. Pisc. birds	-	-	-	-	-	-	-	-	-	-	-	
9. Adult pollock 2+	-	-	-	-	-	-	-	-	-	-	-	
10. Juv. pollock 0-1	-	-	-	-	-	-	-	-	-	-	-	
11. O.Dem.Fish	-	-	-	-	-	-	-	-	-	-	-	
12. Large Flatfish	-	-	-	-	-	-	-	-	-	-	-	
13. Small Flatfish	1.00	-	-	-	-	-	-	-	-	-	-	
14. Pelagics	0.29	1.00	-	-	-	-	-	-	-	-	-	
15. Deepwater fish	0.14	0.21	1.00	-	-	-	-	-	-	-	-	
16. Jellyfish	0.07	0.28	0.13	1.00	-	-	-	-	-	-	-	
17. Cephalopods	0.27	0.86	0.38	0.17	1.00	-	-	-	-	-	-	
18. Benth.P.Feeders	0.72	0.54	0.17	0.11	0.54	1.00	-	-	-	-	-	
19. Infauna	0.00	-	0.00	-	-	0.47	1.00	-	-	-	-	
20. Epifauna	0.43	0.06	0.02	0.01	0.06	0.76	0.85	1.00	-	-	-	
21. Large Zoops	0.00	0.03	0.00	0.29	0.00	0.08	0.14	0.14	1.00	-	-	
22. Herb. Zoops.	-	-	-	-	-	-	-	-	0.89	1.00	-	
23. Phytoplankton	-	-	-	-	-	-	-	-	-	-	-	